



Promoting digital transformation and social innovation in VET
for better access of deaf students to the labour market

2022-1-PL01-KA220-VET-000086953

3D4DEAF DUAL TRAINING PACK

Module 1: 3D TECHNOLOGIES

Topic 2: The 3D Printing Process





3D4DEAF

TOPIC:

The 3D Printing Process

SUB TOPICS:

- Introduction to Tinkercad online software (theoretical part)
- Introduction to CURA slicing software (theoretical part)
- Preparation of 3D Printer

Developed by:

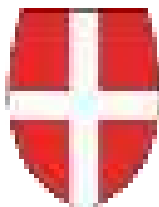

UNIVERSITÀ DEL
TORINO



Project Consortium

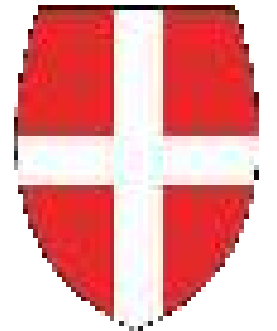

IEPIL INSTITUTO DE INVESTIGACIONES PSICOLÓGICAS
ESTORISÓ

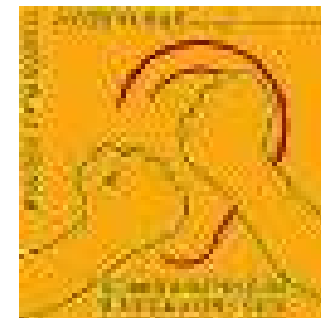

Content of presentation

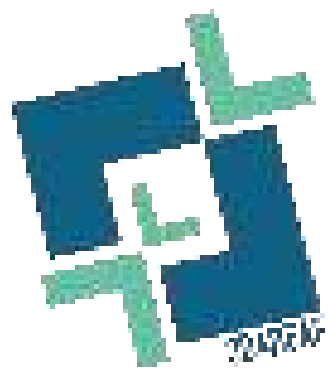

Sub-Topic 1:

Introduction to Tinkercad online software (theoretical part)

Sub-Topic 2:

Introduction to CURA slicing software (theoretical part)

Sub-Topic 3:

Preparation of 3D Printer

Topic Description

Tinkercad is a user-friendly, web-based 3D design and modeling platform that empowers individuals to create, modify, and prototype digital designs. Developed by Autodesk, Tinkercad is particularly popular for its simplicity, making it an ideal entry point for beginners and educational settings.



Learning outcomes

Sub-topic 1: Introduction to Tinkercad online software (theoretical part)

| Module 1: 3D Technologies Topic 2 : The 3D Printing Process | | |
|--|---|--|
| KNOWLEDGE | SKILLS | ATTITUDES |
| Sub-topic 1: Introduction to Tinkercad online software (theoretical part) | | |
| STARTERS | <ul style="list-style-type: none">• Introduction to the basic concepts of Tinkercad online software | <ul style="list-style-type: none">• Developing the ability to model 3D objects before printing requires knowledge of various measurements and the assembly of joined pieces.• Creating the shapes and scale of the object in 3D dimension Utilizing tools in the software Awareness of materials for assembly |

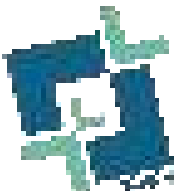

Sub-topic 1: Introduction to Tinkercad online software (theoretical part)

- TinkerCAD is a widely used online platform that offers a user-friendly and approachable way to generate, craft, and simulate **3D models**.
- It is a great tool suitable for newcomers, students, enthusiasts, and even professionals, and they can use it without the necessity of complex software or costly equipment.
- To visit the TinkerCAD software click on the following [link](#)



Sub-topic 1: Introduction to Tinkercad online software (theoretical part)

TinkerCAD is great for beginners who want to build their first CAD models. Users can quickly learn the drag and drop interface to create unique and complex designs.



Sub-topic 1: Introduction to Tinkercad online software (theoretical part)

Tinkercad Compatible Devices:

Tinkercad is a web-based application, which means that it can be used on a wide range of devices with access to an Internet browser. Listed below are some of the devices commonly used to access and work with Tinkercad:

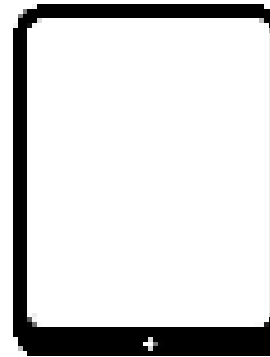
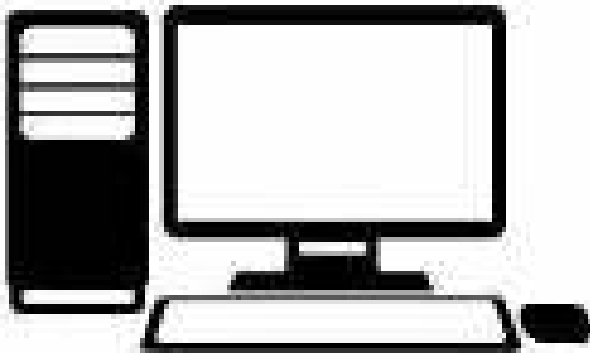

Sub-topic 1: Introduction to Tinkercad online software (theoretical part)

STEP 1

STEP 2

STEP 3

STEP 4



The idea

**First, choose an object you want to create.
It can be anything from a simple screw to a complex toy.**

**We recommend that you start with basic projects basics
until you feel more confident in developing complex designs.**

Sub-topic 1: Introduction to Tinkercad online software (theoretical part)

STEP 1

STEP 2

STEP 3

STEP 4



Designing the model

The main stage is the design of the actual model.

After you have decided what you want to make, you need to use CAD software that can help you create a first draft of the model.

Sub-topic 1: Introduction to Tinkercad online software (theoretical part)

STEP 1

STEP 2

STEP 3

STEP 4



Convert it to STL

It is necessary to convert the model to STL format when completed. The majority of available CAD software has built-in functions that allow you to export the model to STL format.

After you have converted the model to .STL format, you will be halfway to obtaining a 3D printable file.

Sub-topic 1: Introduction to Tinkercad online software (theoretical part)

STEP 1

STEP 2

STEP 3

STEP 4

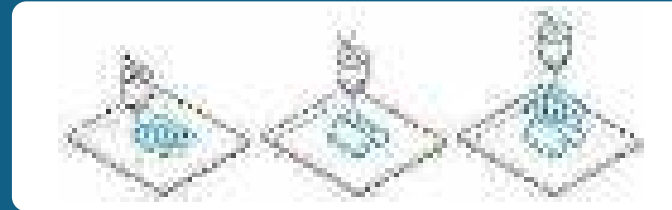

Slicing it

The fourth step requires "slice up" the model into layers. In this stage, the 3D model is converted into a set of instructions that the printer can understand.

This is the last phase, which involves the use of software, at the end of which you get the final G-code file that the printer is able to recognize.

Sub-topic 1: Introduction to Tinkercad online software (theoretical part)

Perspective projections

Perspective projections are drawings that attempt to reproduce what the human eye actually sees when looking at a specific object.

There are three types of perspective projections: one-point, two-point and three-point.

The points of perspective are called vanishing points.

Sub-topic 1: Introduction to Tinkercad online software (theoretical part)

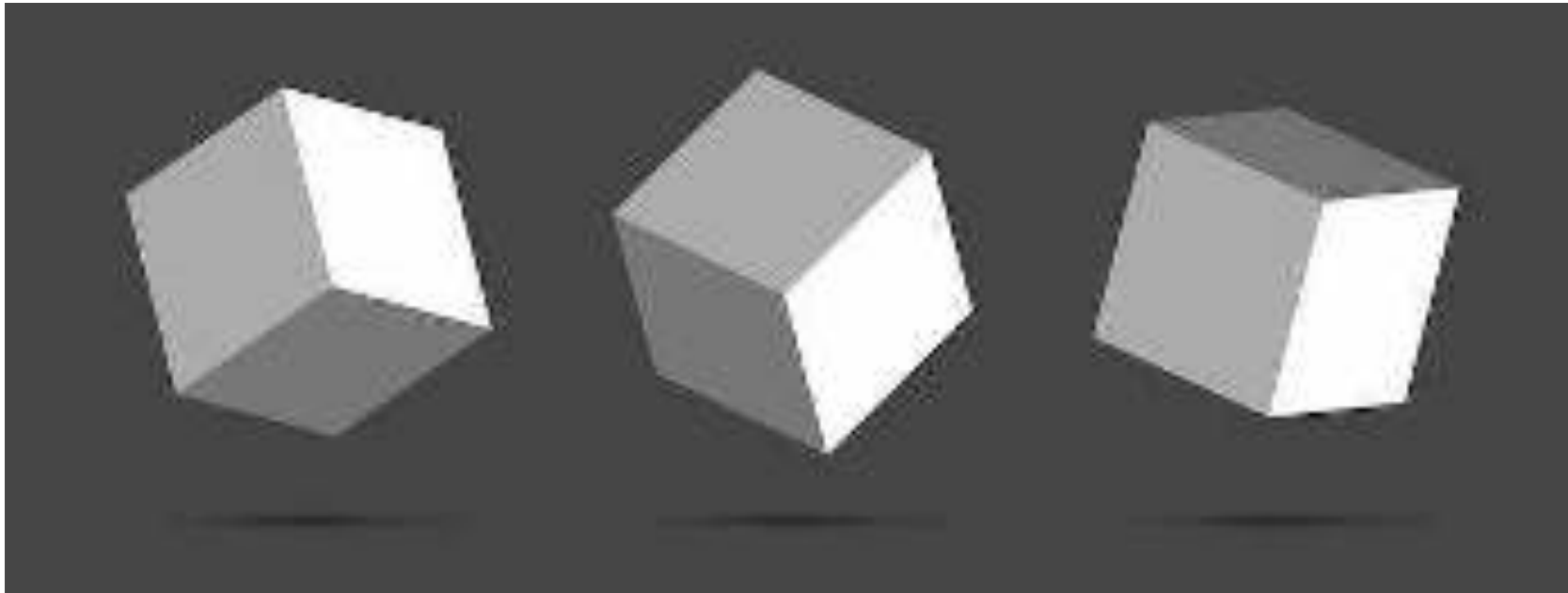

Sub-topic 1: Introduction to Tinkercad online software (theoretical part)

What are the main features of Tinkercad?

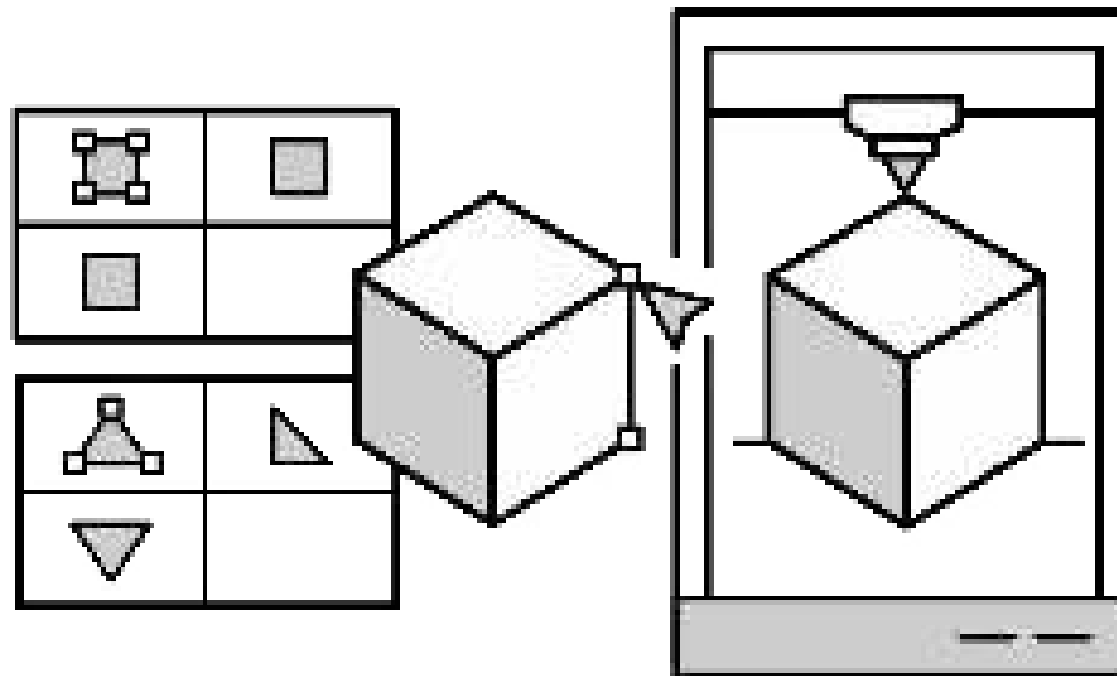

Sub-topic 1: Introduction to Tinkercad online software (theoretical part)

Tinkercad interface

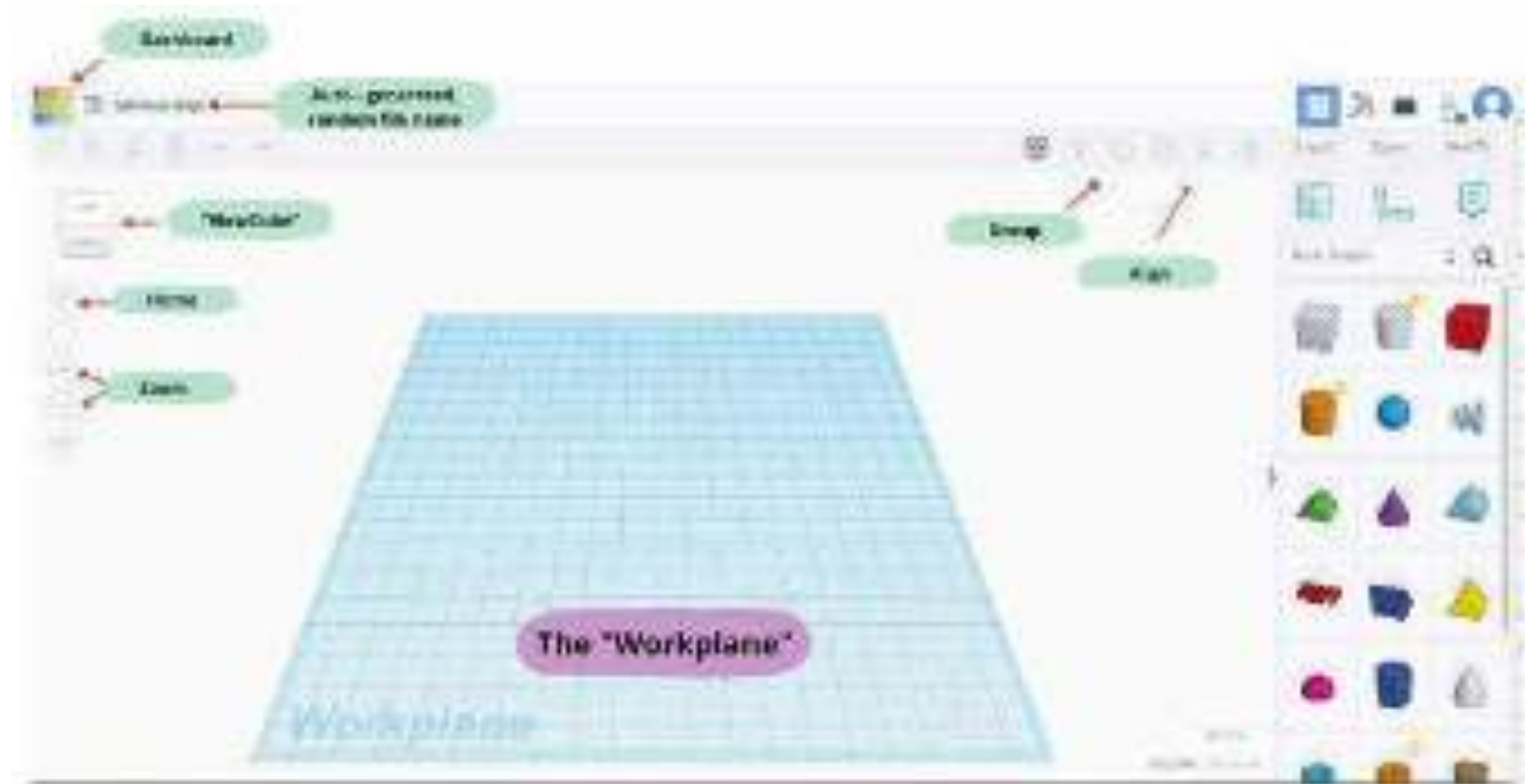

Sub-topic 1: Introduction to Tinkercad online software (theoretical part)

Mouse navigation

You can use the tools to the left of the worktable or the mouse to manipulate the worktable. Use the mouse to:

- Zoom in and out with the mouse wheel.
- Rotate the worktable with right-click and drag.
- Change the view by clicking to the side of the "View Cube"

- Return to the default view perspective by clicking on the house icon.

Sub-topic 1: Introduction to Tinkercad online software (theoretical part)

The menu of shapes

The shapes menu is located on the right side of the interface. You will use these shapes to design your object.

Practice moving the shapes by clicking and dragging some of them on the work..



Sub-topic 1: Introduction to Tinkercad online software (theoretical part)

Editing 3D shapes

Note the small white boxes around the shape. Stretch or shrink the shape by clicking and dragging the small white squares at the corners. To change the height of the shape, click and drag the small white square on the top of the shape.

You can also change the size by selecting and entering the desired numbers. The numbers you see are the dimensions in millimeters.

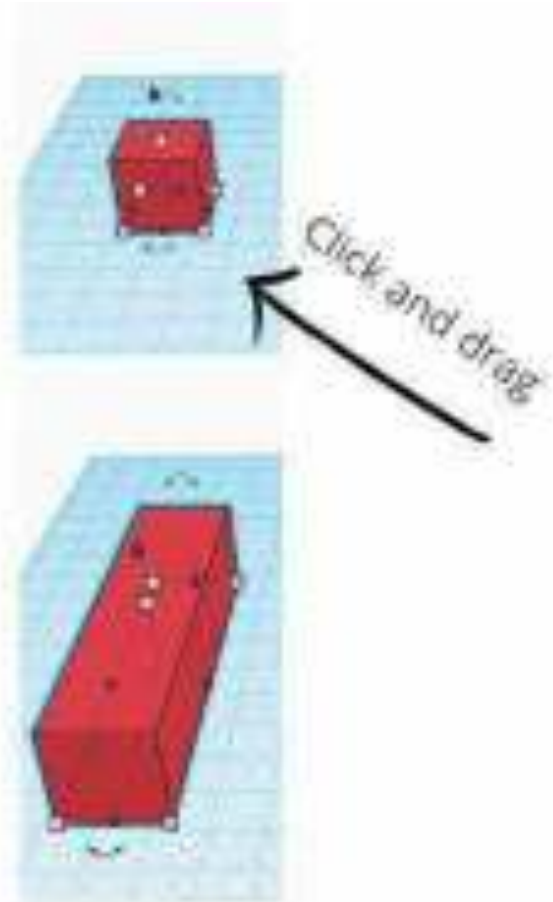

Sub-topic 1: Introduction to Tinkercad online software (theoretical part)

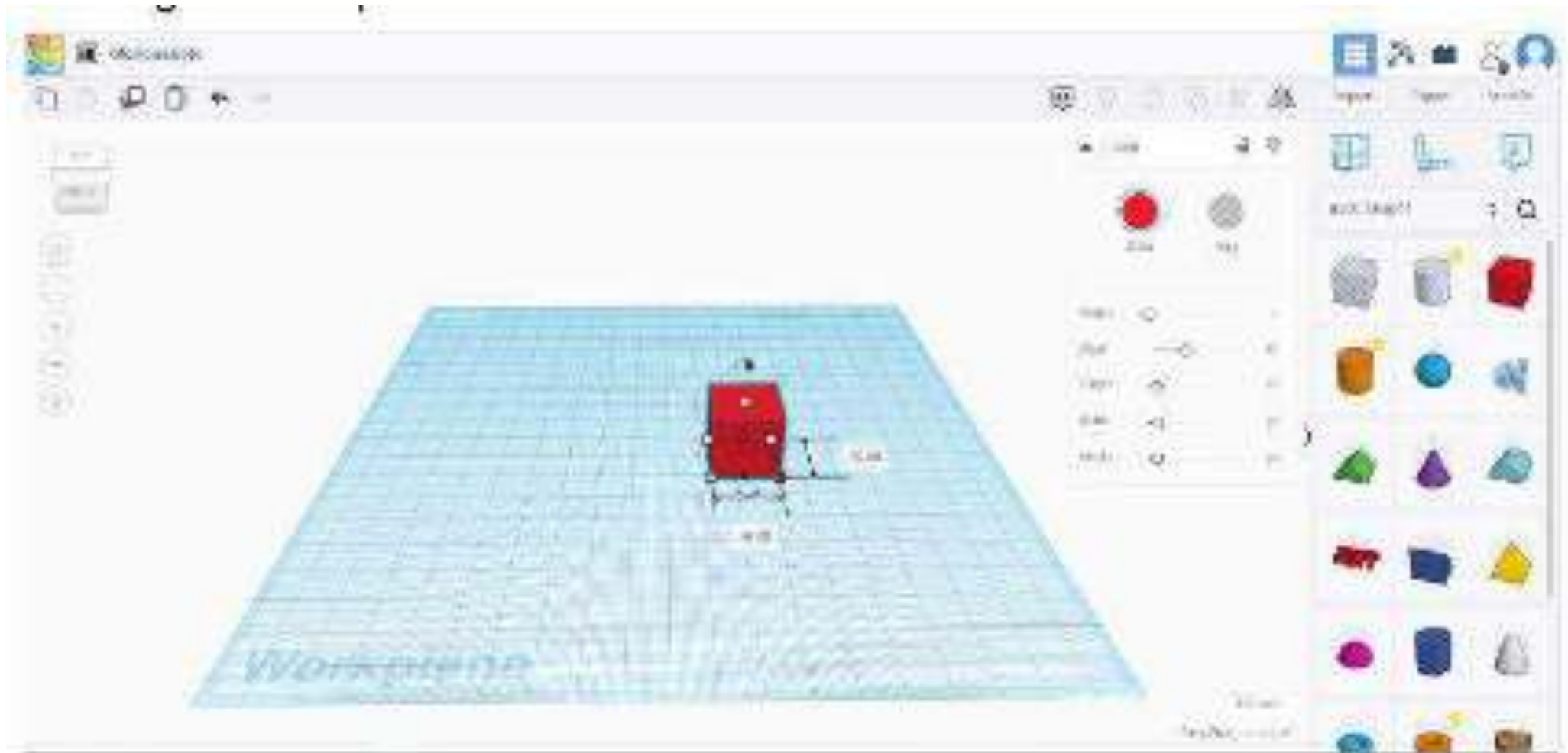

Sub-topic 1: Introduction to Tinkercad online software (theoretical part)

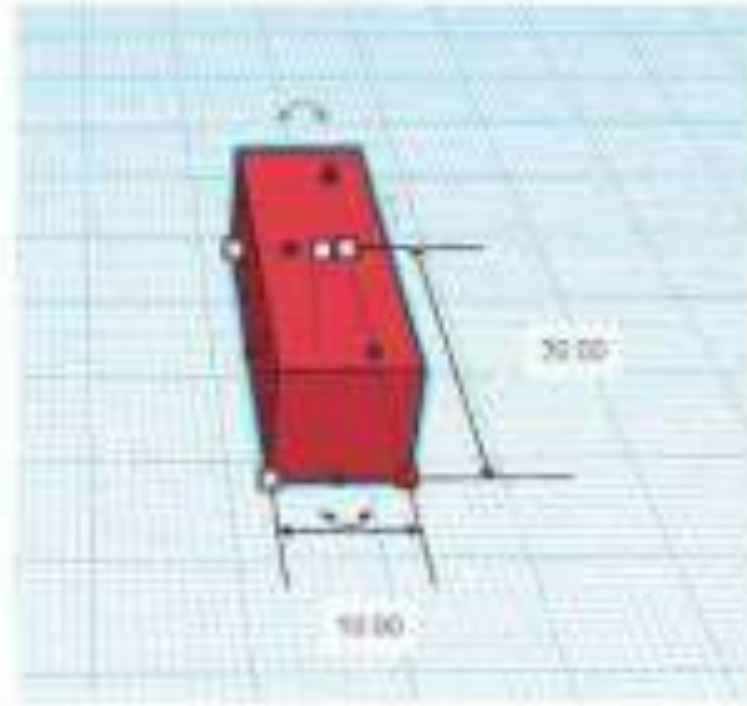

Width: 10 millimetres (mm)

Length: 30 mm

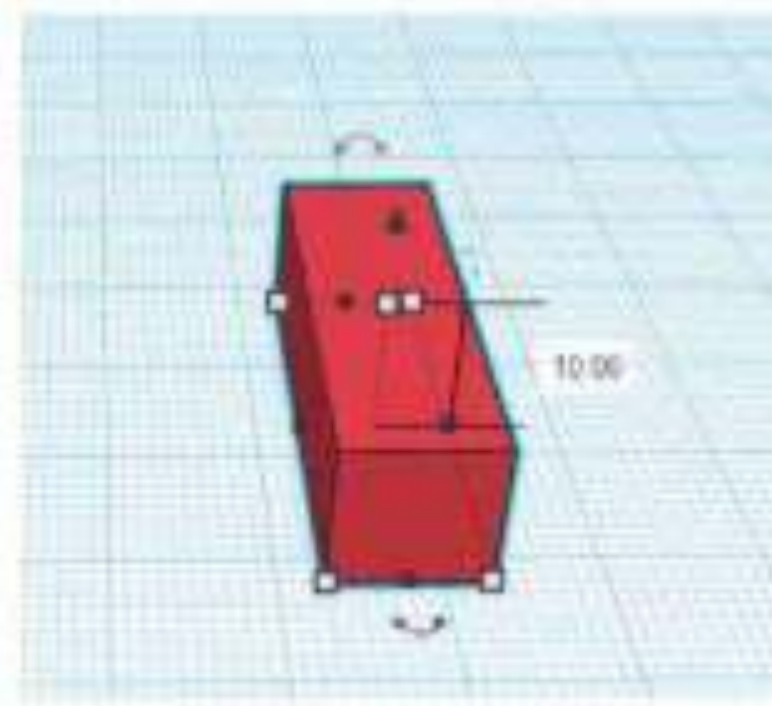

Height: 10 mm

Sub-topic 1: Introduction to Tinkercad online software (theoretical part)

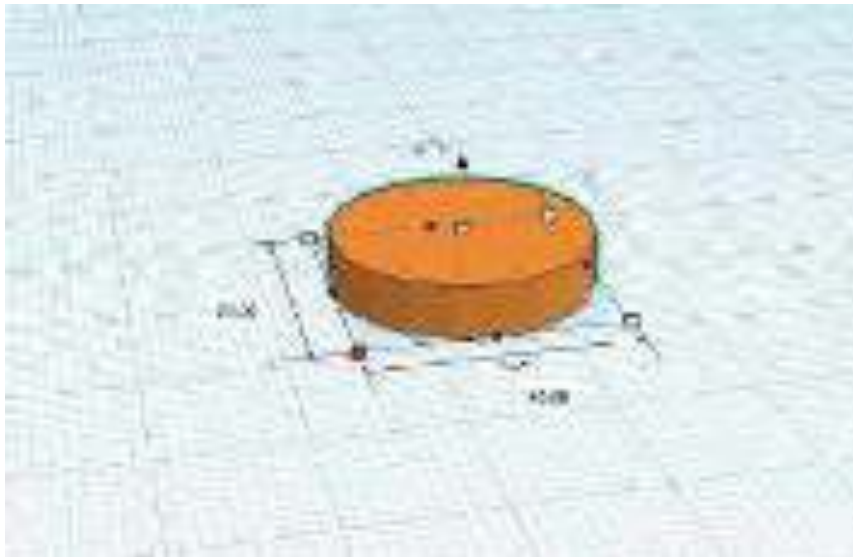

Width: 20 millimetres (mm)
Length: 20 mm

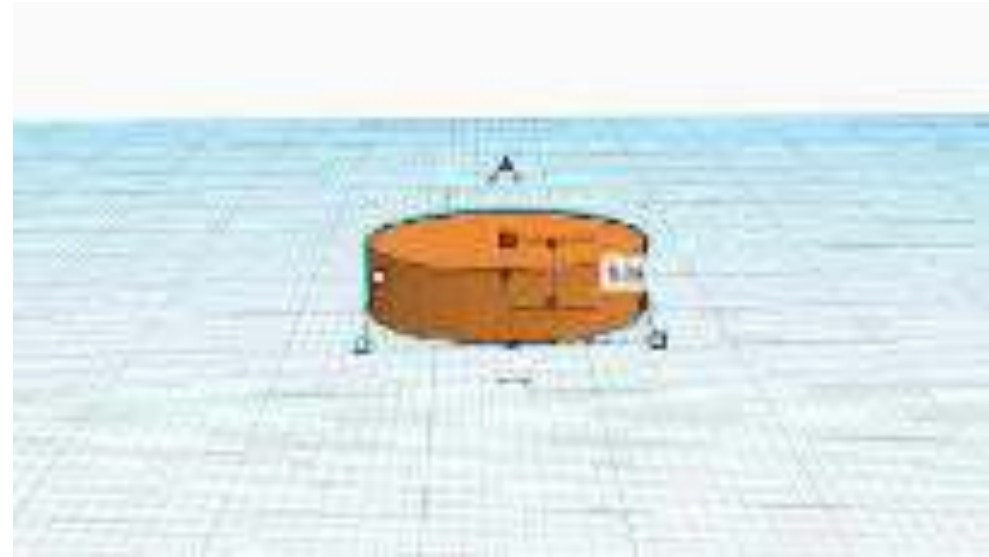

Height: 5 mm

Sub-topic 1: Introduction to Tinkercad online software (theoretical part)

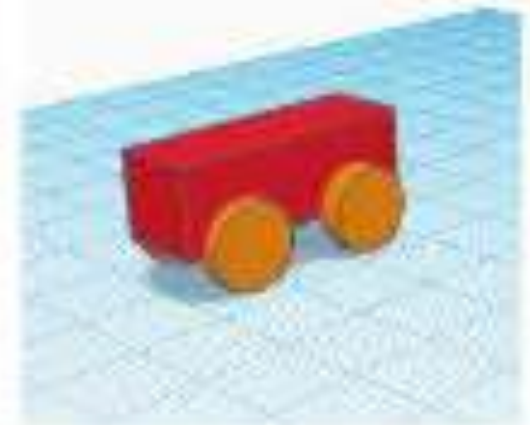
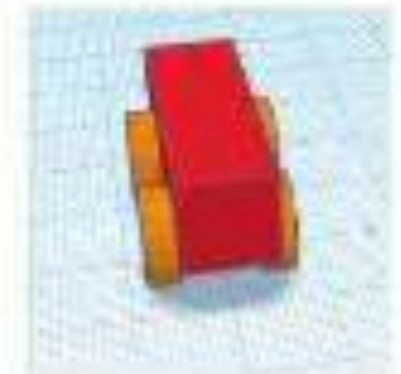
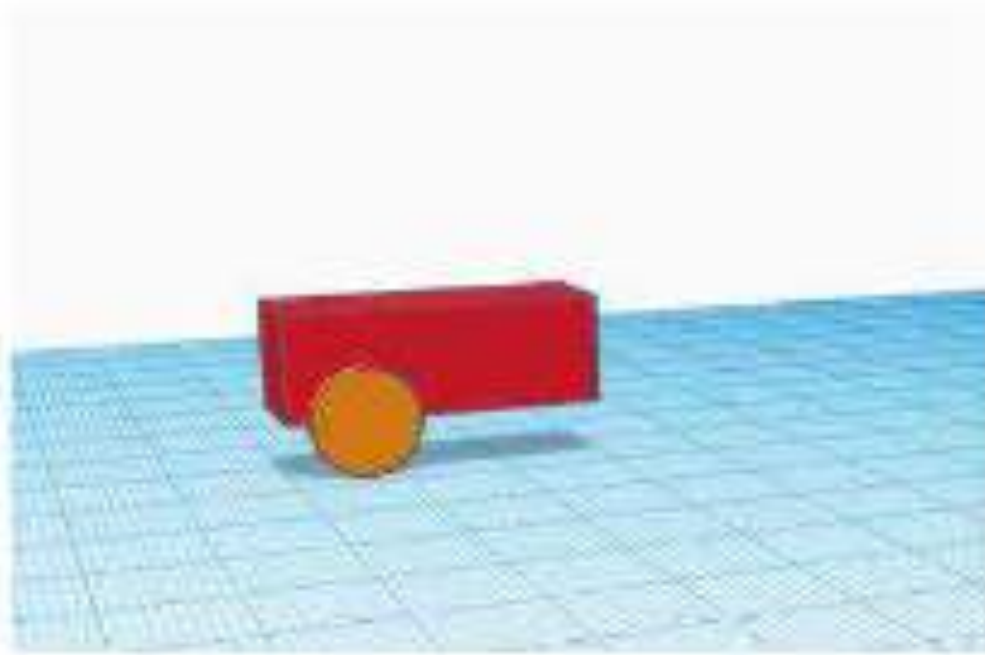

Sub-topic 1: Introduction to Tinkercad online software (theoretical part)

Creating a hole



Sub-topic 1: Introduction to Tinkercad online software (theoretical part)

➤ Placing an object on Tinkercad

Placing shapes is one of the most common actions taken in Tinkercad and is simply the act of getting a shape into the design and onto the Workplane.

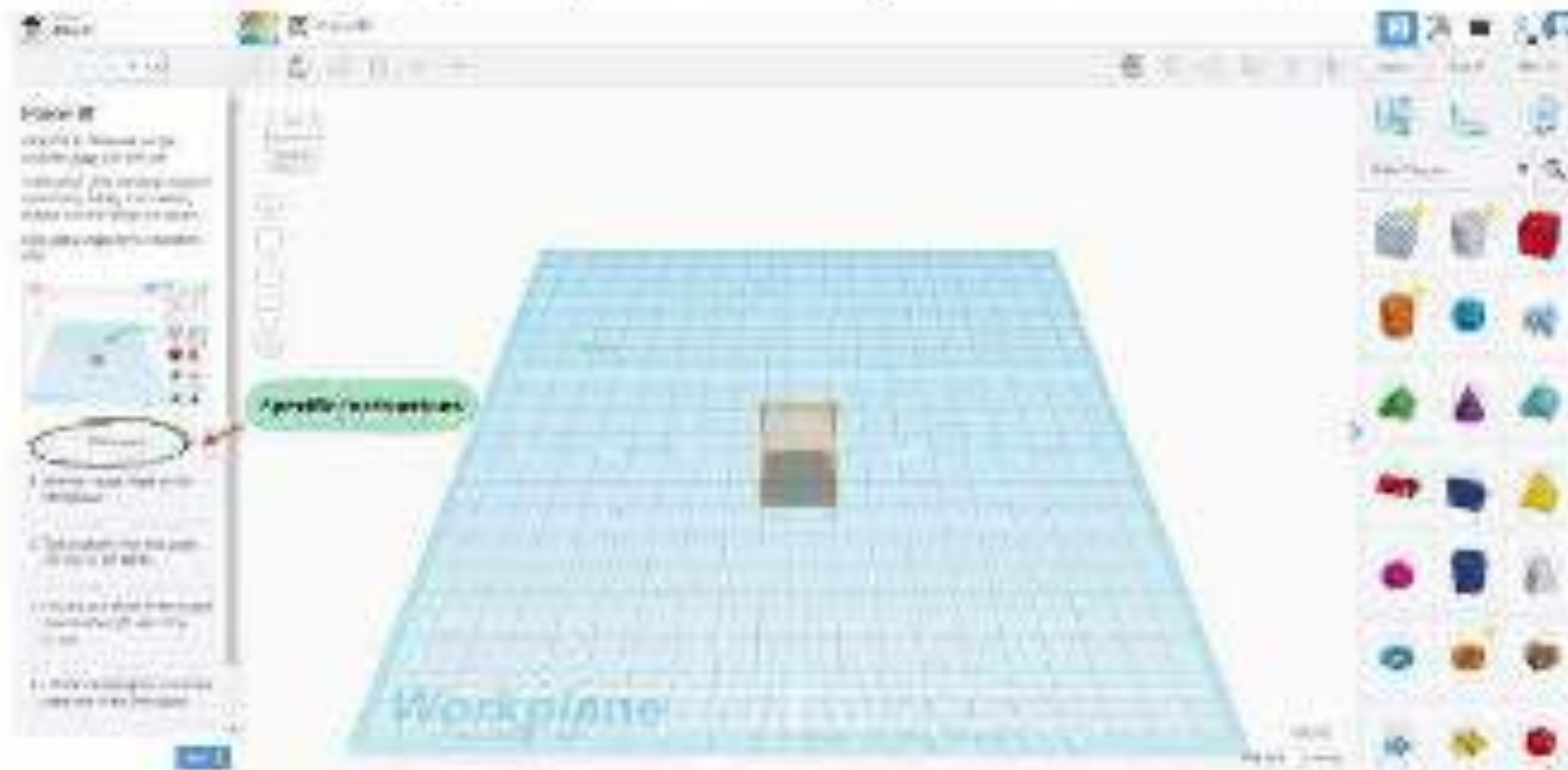

Sub-topic 1: Introduction to Tinkercad online software (theoretical part)

➤ Viewing an object from different perspectives

While creating designs it helps to see your shapes from all sides.

The **ViewCube** (located at the top left of Tinkercad) will help you look around.

Let's learn how you can change your view.

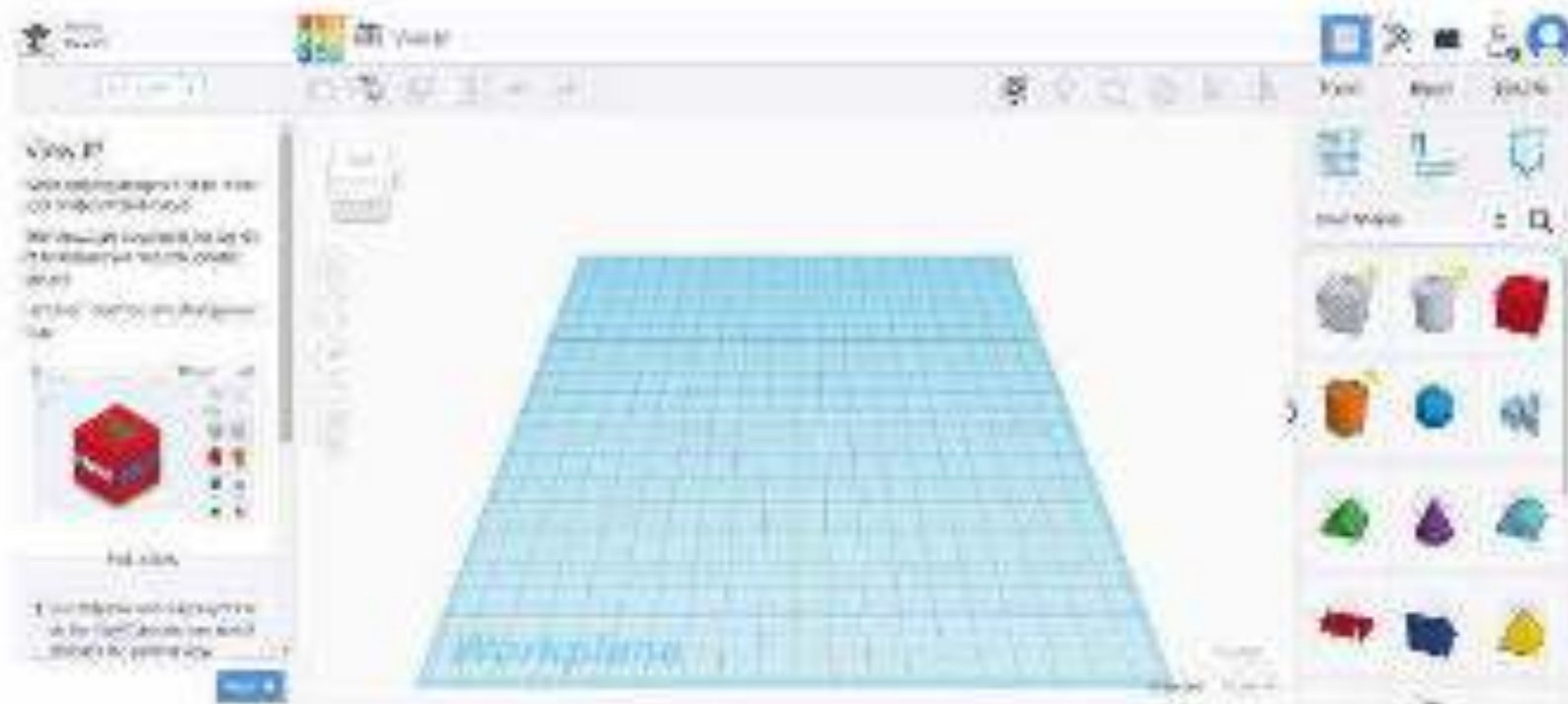

Sub-topic 1: Introduction to Tinkercad online software (theoretical part)

➤ Moving an object on the Workplane

Moving, rotating, and arranging basic shapes is what allows creativity in Tinkercad. The combination of simple shapes allows the creation of more complex and creative designs.

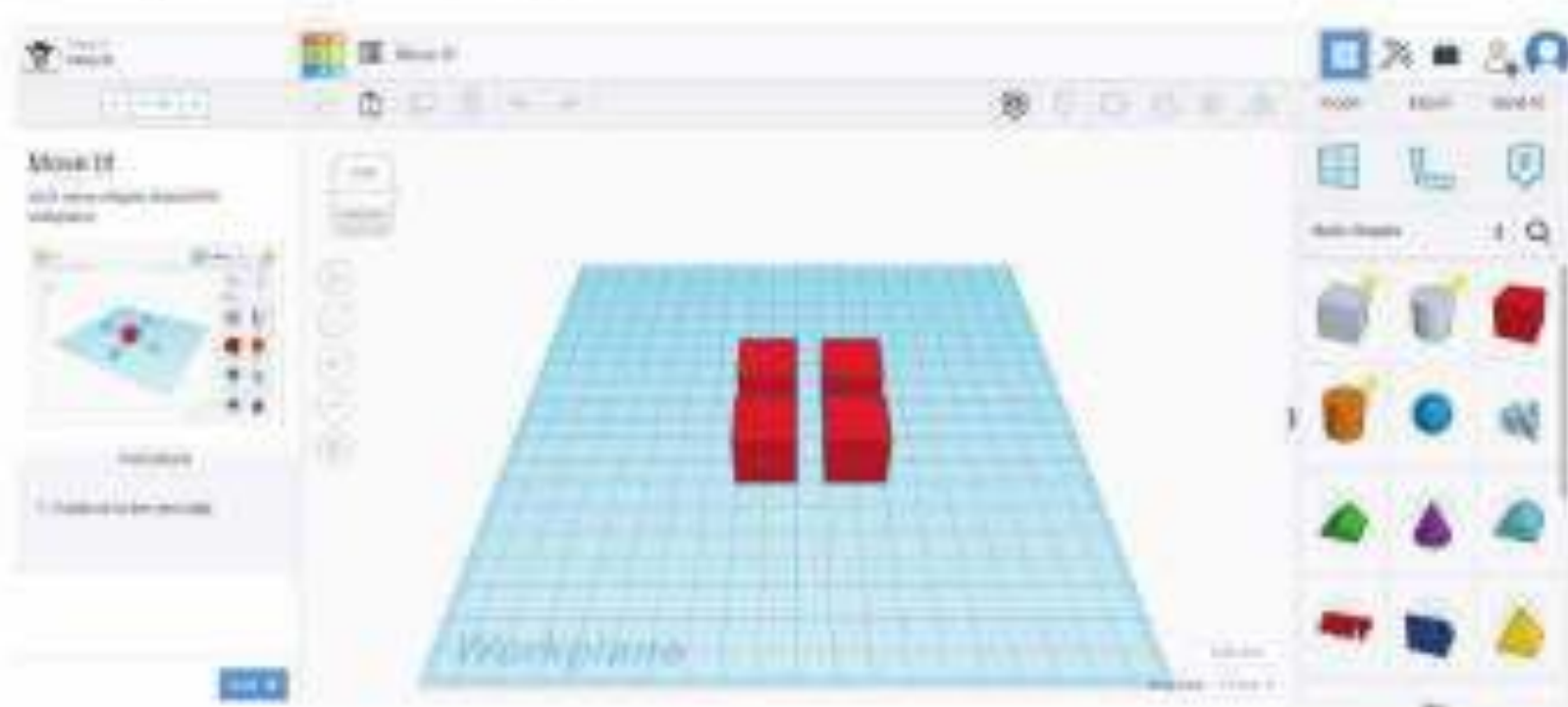

Sub-topic 1: Introduction to Tinkercad online software (theoretical part)

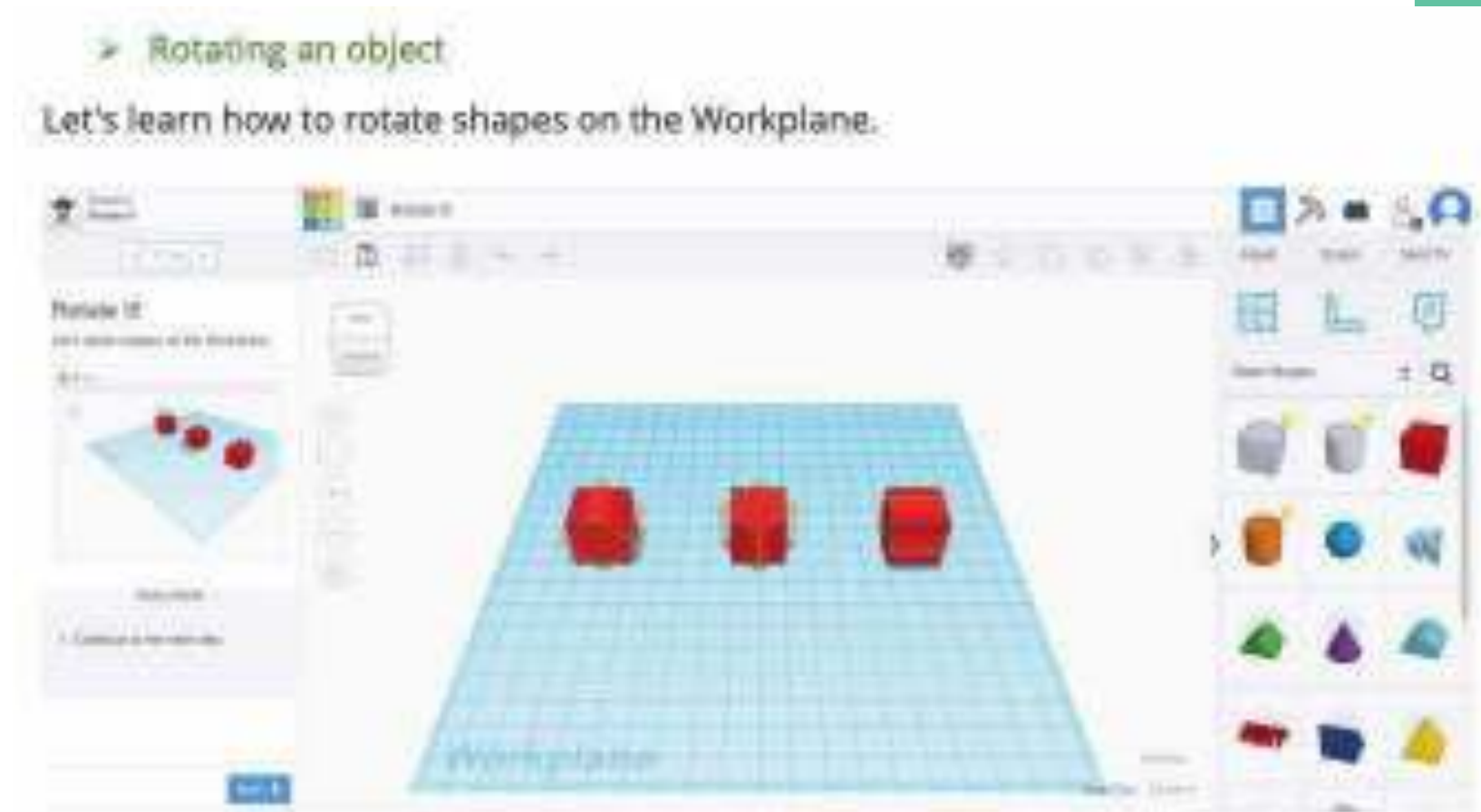

Sub-topic 1: Introduction to Tinkercad online software (theoretical part)

➤ Sizing on Tinkercad

Learn how to change a shape's scale by sizing it up or down.

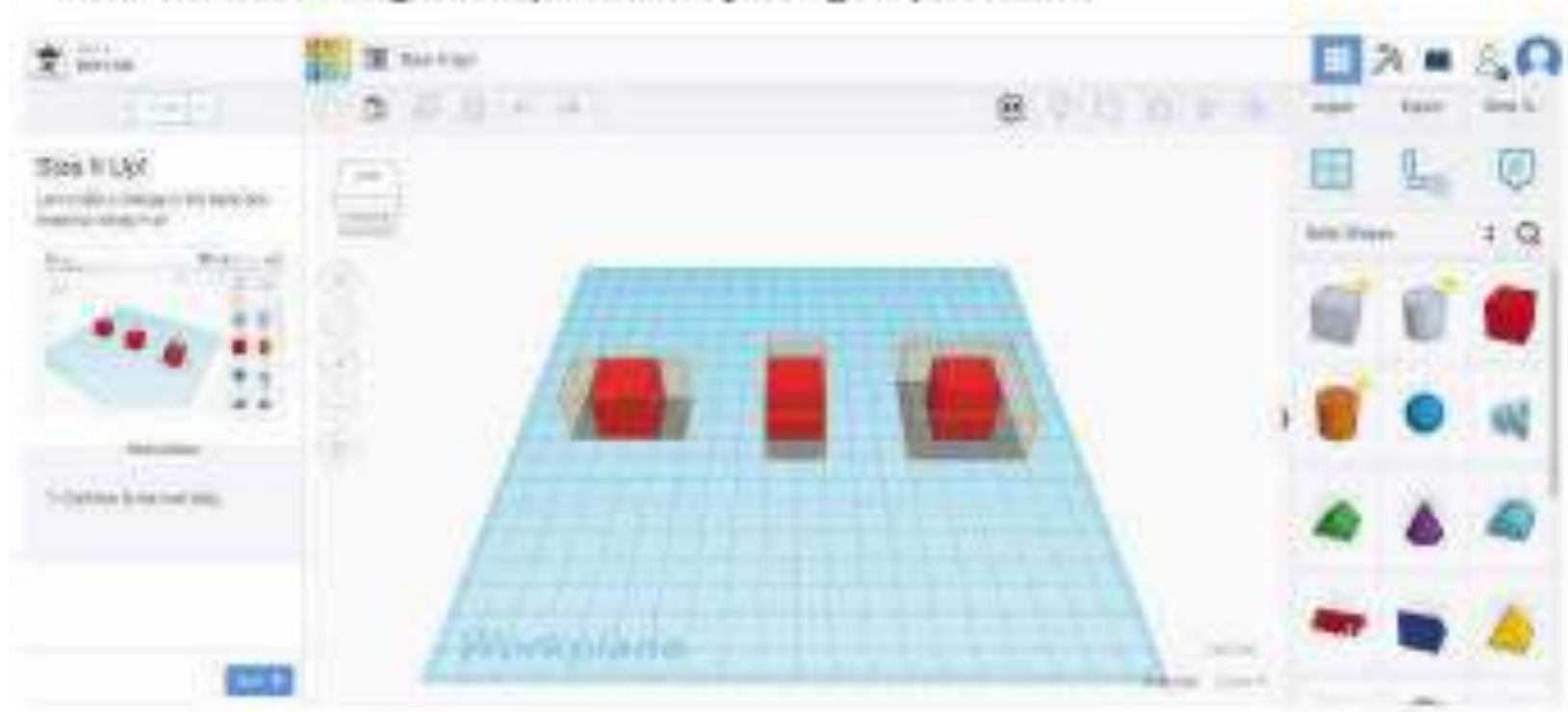

Sub-topic 1: Introduction to Tinkercad online software (theoretical part)

➤ Grouping shapes

Grouping shapes lets you combine shapes into a single object. Any shape in the group can be used to add or remove material from the other shapes it is combined with.

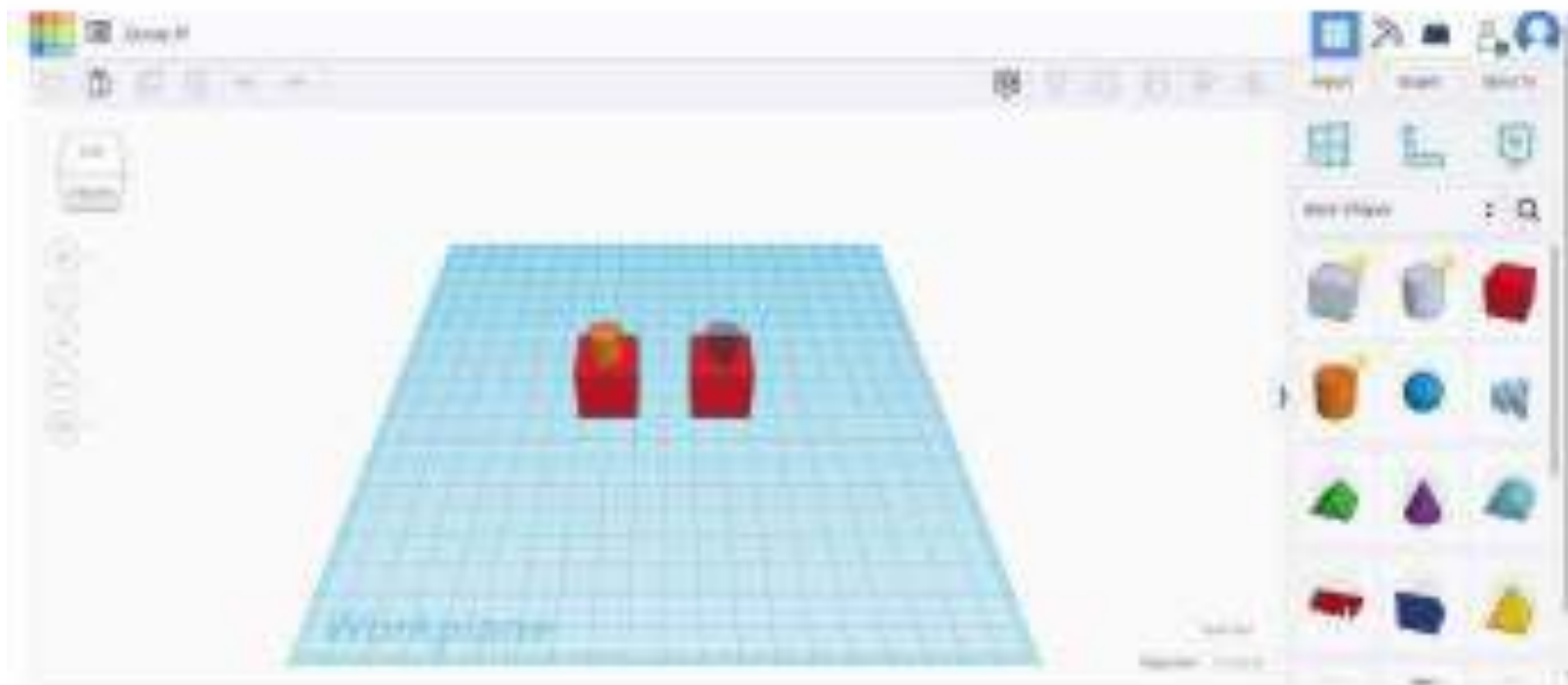

Sub-topic 1: Introduction to Tinkercad online software (theoretical part)

➤ Aligning shapes

While building you may need to line up shapes. Let's try aligning some shapes.

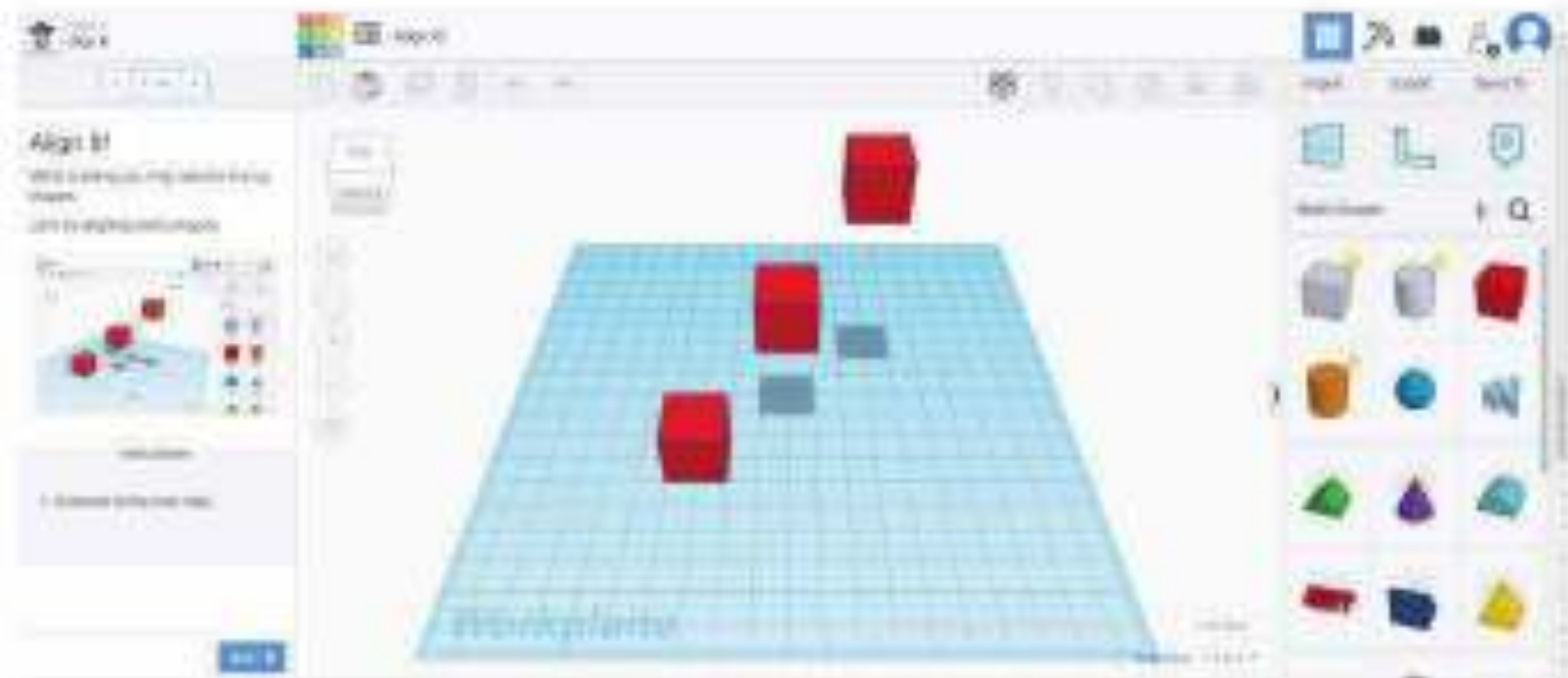

Sub-topic 1: Introduction to Tinkercad online software (theoretical part)

➤ Creating Holes

In this project you will learn how to remove material from another shape using the hole feature.

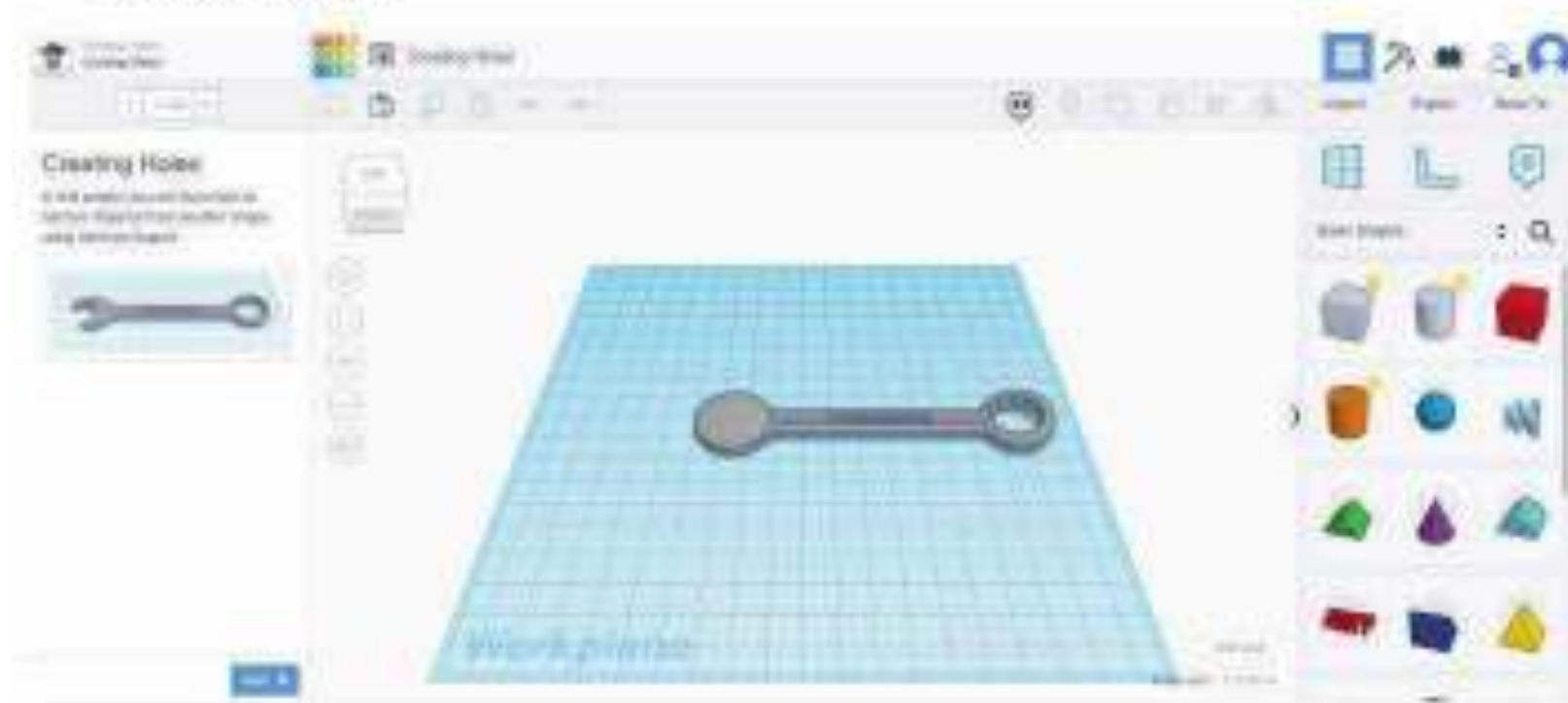

Sub-topic 1: Introduction to Tinkercad online software (theoretical part)

Small Projects to practice on

Sub-topic 1: Introduction to Tinkercad online software (theoretical part)

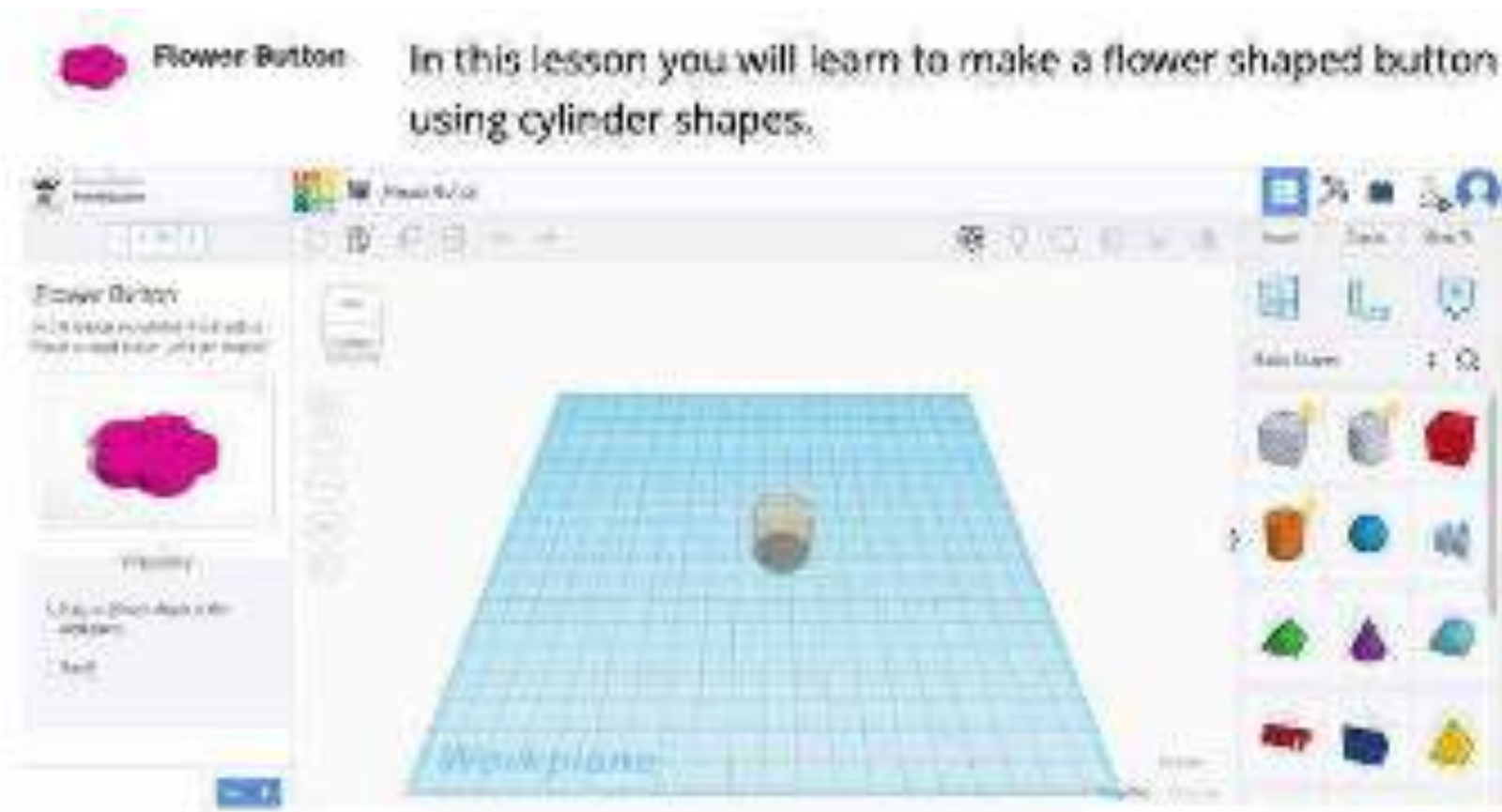

Sub-topic 1: Introduction to Tinkercad online software (theoretical part)

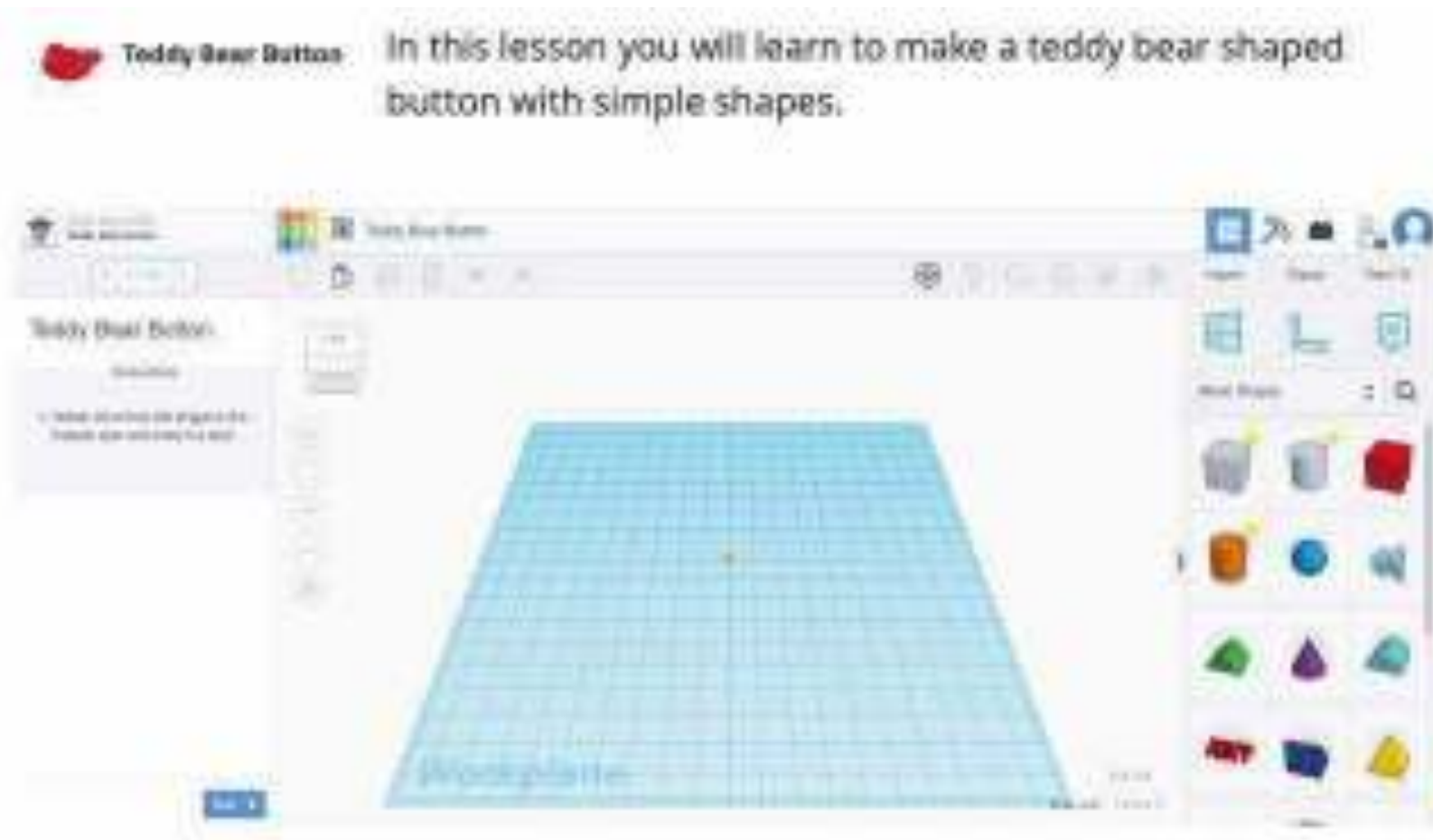

Sub-topic 1: Introduction to Tinkercad online software (theoretical part)

Bowling Exercise

- Drag and drop the cylinder onto the Workplane.
- Create a total of 6 cylinders on the Workplane using the duplicate or copy and paste methods.
- Position the cylinders so that they form a triangle (three in the back row, followed by two in the middle row, followed by one in the front row).
- Drag and drop a sphere on to the Workplane.
- Lift the sphere 2mm up off the Workplane.
- Take a look of the finished exercise from multiple angles, practising on the rotation and different views of the Workplane.



Figure 31 / Bowling exercise

Source: www.proambitions.com

Sub-topic 1: Introduction to Tinkercad online software (theoretical part)

Tinker Cup

- Add a cylinder to the Workplane and change the dimensions to... (Side: 60, Bevel: .75, Segment: 10, Length: 20, Width: 20, Height: 30)
- Add another cylinder to the Workplane and change its dimensions to... (Side: 60, Bevel: 0, Segment: 1, Length: 17.5, Width: 17.5, Height: 32)
- Turn the second cylinder into a hole.
- Using the Alignment Tool, place the hole cylinder in the centre of the Solid Cylinder, making sure the hole cylinder is 2mm off the Workplane (to ensure it doesn't cut off the bottom of the cup when grouped).
- Group them together to create your mug.

Bonus: create a handle using a torus and attach to the cup. (Make sure the handle does not protrude into the inside of the cup).



Figure 3D / TinkerCup exercise

Source: promeambitions.com

Sub-topic 1: Introduction to Tinkercad online software (theoretical part)

Learning center

3D Project

Circuits

Codeblock

Sub-topic 1: Introduction to Tinkercad online software (theoretical part)

Learning center

3D Project

Learn how to use 3D design

These initial projects are an ideal starting point for becoming familiar with all of Tinkercad's activities.

Sub-topic 1: Introduction to Tinkercad online software (theoretical part)

3D Project

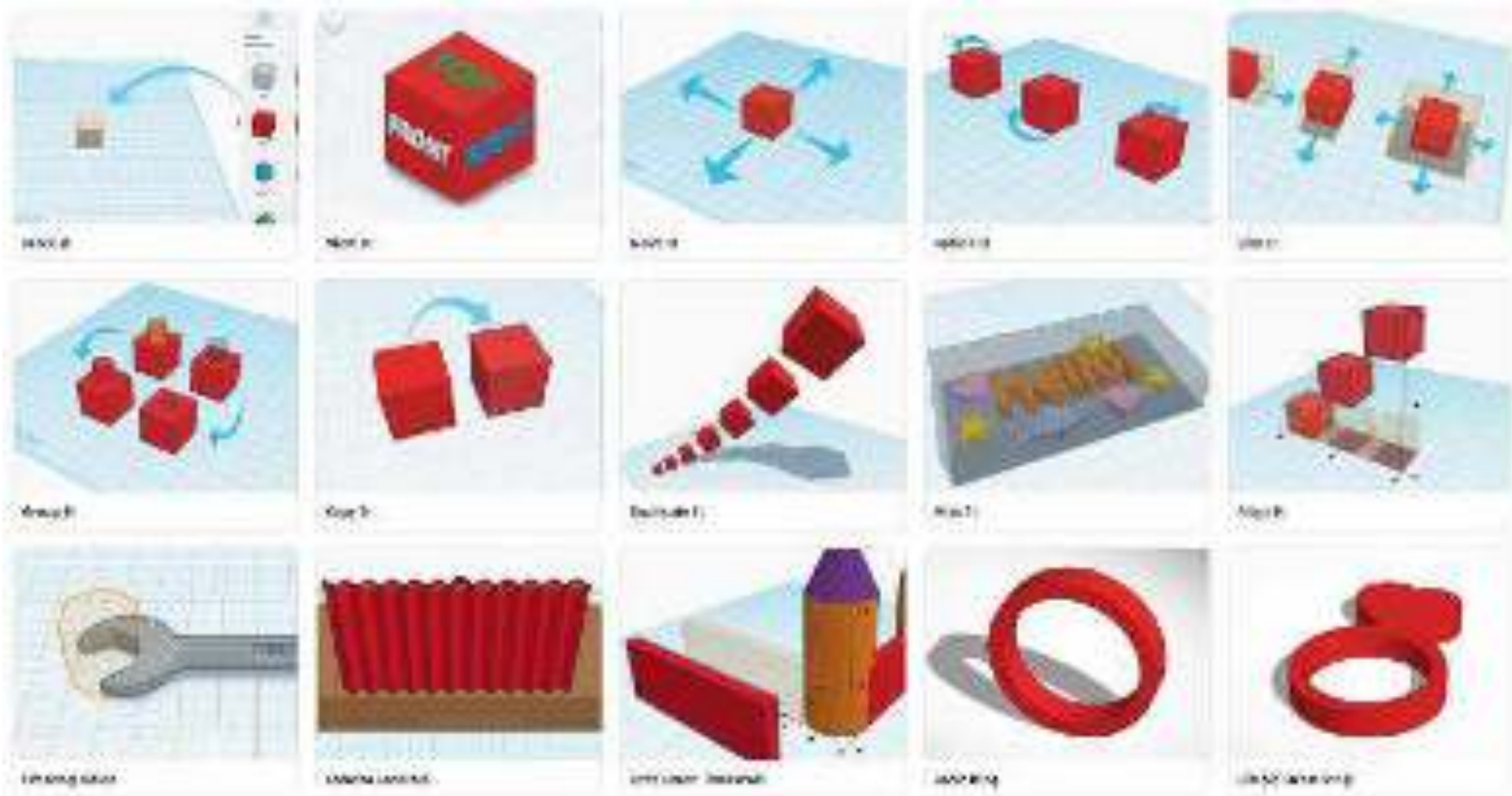

Sub-topic 1: Introduction to Tinkercad online software (theoretical part)

3D Project



Sub-topic 1: Introduction to Tinkercad online software (theoretical part)

3D Project



Sub-topic 1: Introduction to Tinkercad online software (theoretical part)

3D Project



Sub-topic 1: Introduction to Tinkercad online software (theoretical part)

3D Project



Sub-topic 1: Introduction to Tinkercad online software (theoretical part)

3D Project



Sub-topic 1: Introduction to Tinkercad online software (theoretical part)

Learning center

Circuits

Learn how to use circuits

These initial projects are an ideal starting point for becoming familiar with all of Tinkercad's activities.

Sub-topic 1: Introduction to Tinkercad online software (theoretical part)

Circuits

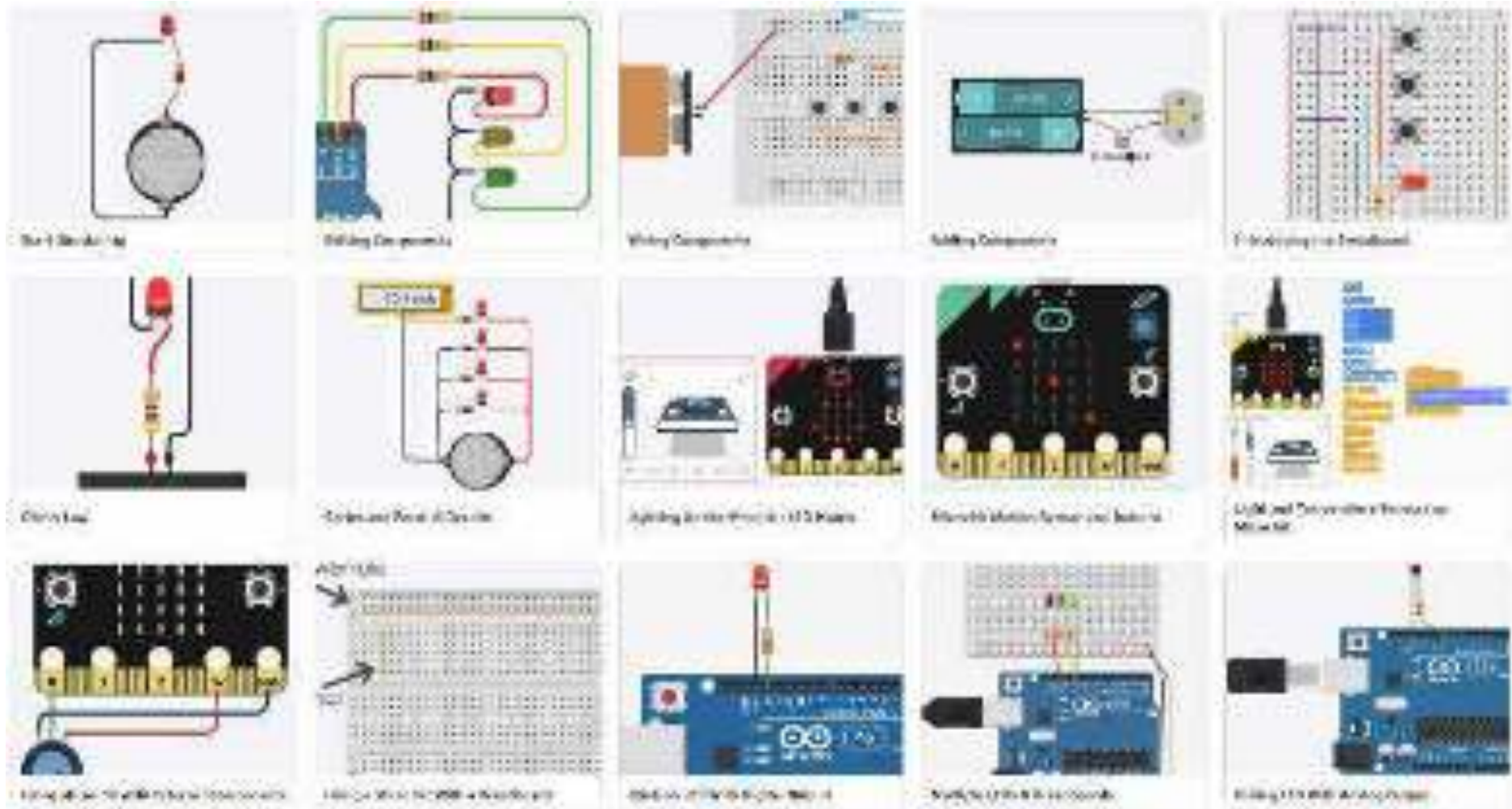

Sub-topic 1: Introduction to Tinkercad online software (theoretical part)

Circuits

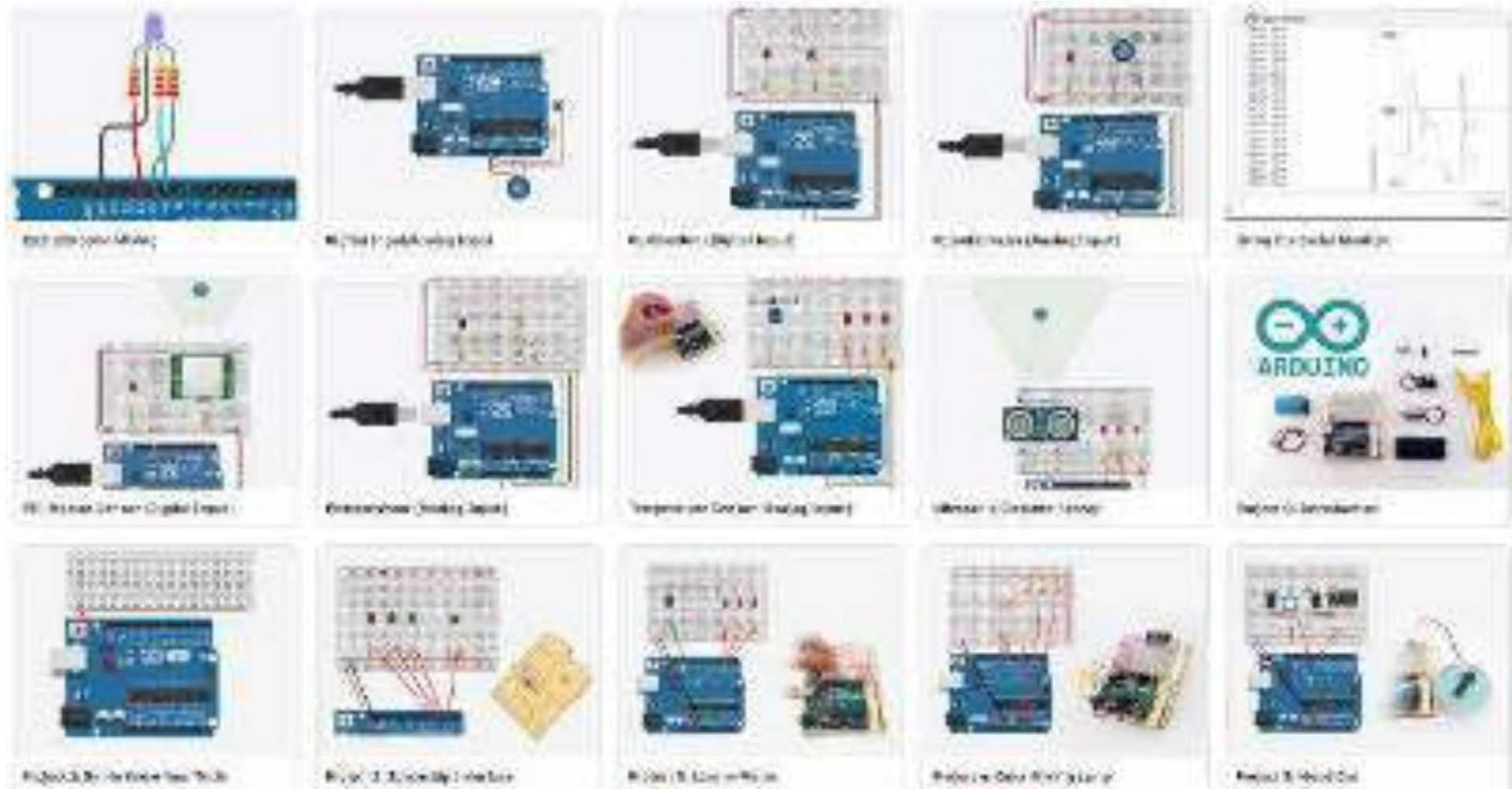

Sub-topic 1: Introduction to Tinkercad online software (theoretical part)

Circuits



Sub-topic 1: Introduction to Tinkercad online software (theoretical part)

Learning center

Codeblock

Learn how to use code blocks

These initial projects are an ideal starting point for becoming familiar with all of Tinkercad's activities.

Sub-topic 1: Introduction to Tinkercad online software (theoretical part)

Codeblock

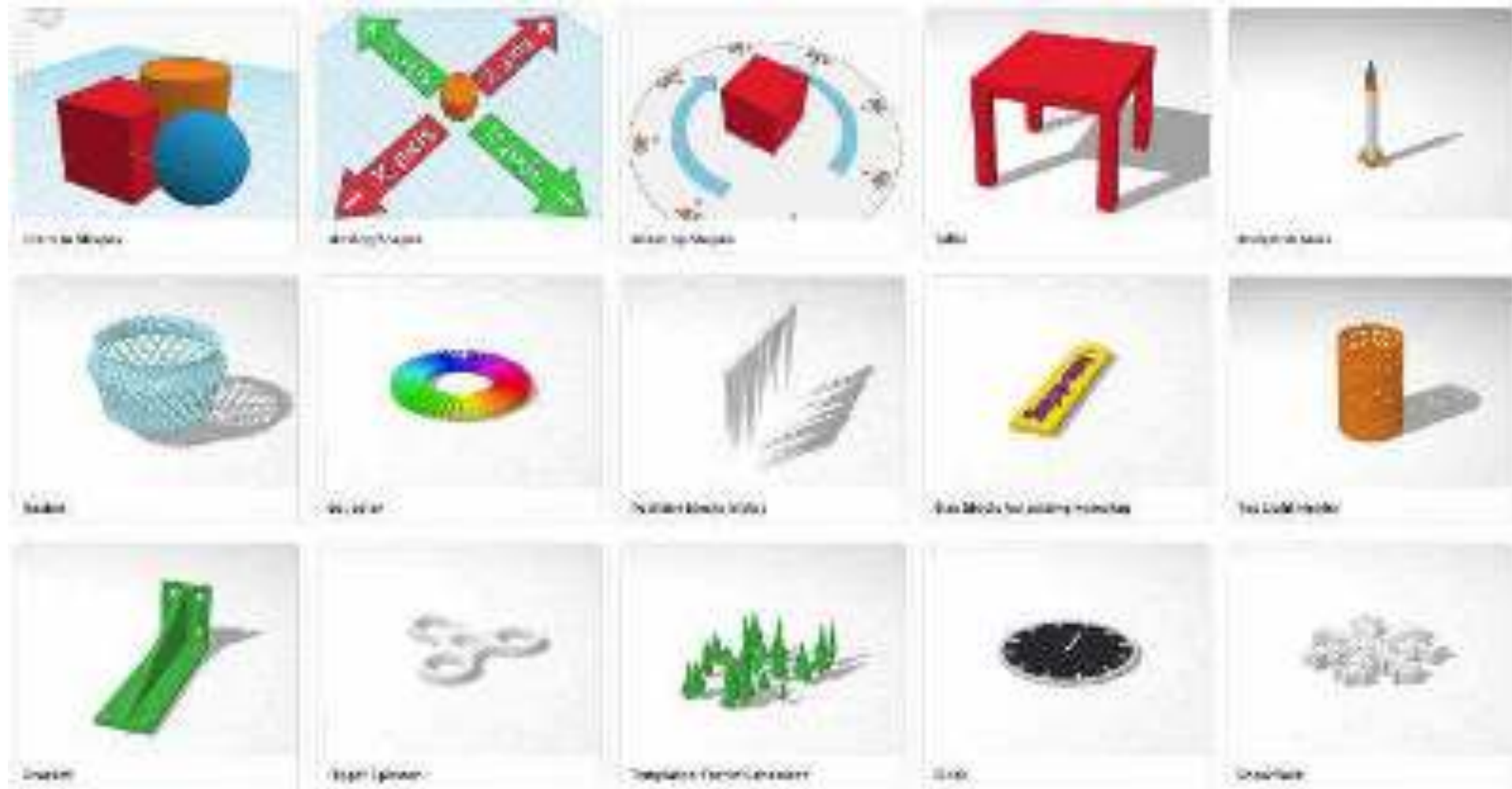

Sub-topic 1: Introduction to Tinkercad online software (theoretical part)

Codeblock



Sub-topic 1: Introduction to Tinkercad online software (theoretical part)



Free lesson plan

Detailed lessons meeting academic standards

Sub-topic 1: Introduction to Tinkercad online software (theoretical part)



ART



COMPUTER
SCIENCE

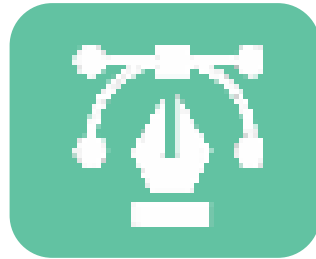

DESIGN

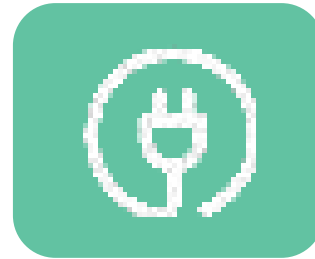

ELECTRONICS

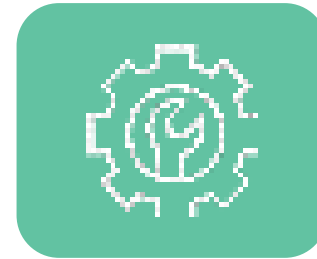

ENGINEERING

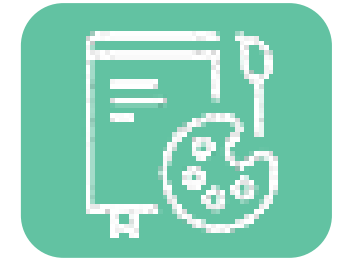

LANGUAGE ARTS

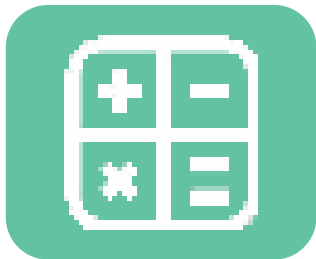

MATH

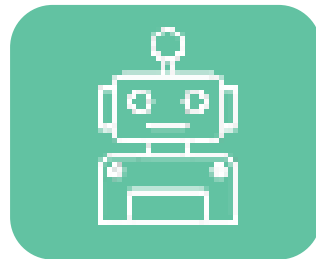

ROBOTICS



SCIENCE

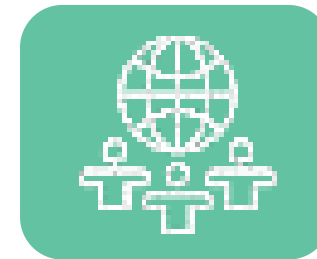

SOCIAL STUDIES

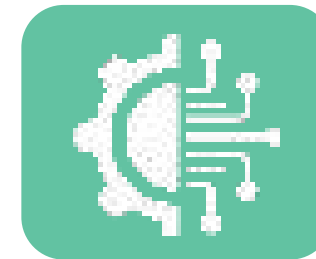

TECHNOLOGY

Sub-topic 1: Introduction to Tinkercad online software (theoretical part)

Lesson plan



Create a MIDI studio in the DAW with Tera in and Tera in out

Video: [Tera in and Tera in out](#)
Project: [Tera in and Tera in out](#)
Components: [Tera in and Tera in out](#)



Create a Piece of Skateable Art

Video: [Create a Piece of Skateable Art](#)
Project: [Create a Piece of Skateable Art](#)
Components: [Create a Piece of Skateable Art](#)



Create a Solar-powered Invention

Video: [Create a Solar-powered Invention](#)
Project: [Create a Solar-powered Invention](#)
Components: [Create a Solar-powered Invention](#)



Program an LED Light Chain

Video: [Program an LED Light Chain](#)
Project: [Program an LED Light Chain](#)
Components: [Program an LED Light Chain](#)



Design Your Dream Room

Video: [Design Your Dream Room](#)
Project: [Design Your Dream Room](#)
Components: [Design Your Dream Room](#)



Revise of the Shopping Cart

Video: [Revise of the Shopping Cart](#)
Project: [Revise of the Shopping Cart](#)
Components: [Revise of the Shopping Cart](#)

Sub-topic 1: Introduction to Tinkercad online software (theoretical part)

Lesson plan



Design a Funnel Solution

Version: 1.0 (2023) | 10 min
Applicable: 10-12 years old (Primary/Elementary)
Competence: 10-12 years old (Primary/Elementary)



Create Your Own Avatar

Version: 1.0 (2023) | 10 min
Applicable: 10-12 years old (Primary/Elementary)
Competence: 10-12 years old (Primary/Elementary)



Level 1: Design that can Move Through a Pipe

Version: 1.0 (2023) | 10 min
Applicable: 10-12 years old (Primary/Elementary)
Competence: 10-12 years old (Primary/Elementary)



Design an Inclusive Play Space

Version: 1.0 (2023) | 10 min
Applicable: 10-12 years old (Primary/Elementary)
Competence: 10-12 years old (Primary/Elementary)



Make Your Own Measuring Tool

Version: 1.0 (2023) | 10 min
Applicable: 10-12 years old (Primary/Elementary)
Competence: 10-12 years old (Primary/Elementary)



Design Thinking for Pollution Problems

Version: 1.0 (2023) | 10 min
Applicable: 10-12 years old (Primary/Elementary)
Competence: 10-12 years old (Primary/Elementary)

Sub-topic 1: Introduction to Tinkercad online software (theoretical part)

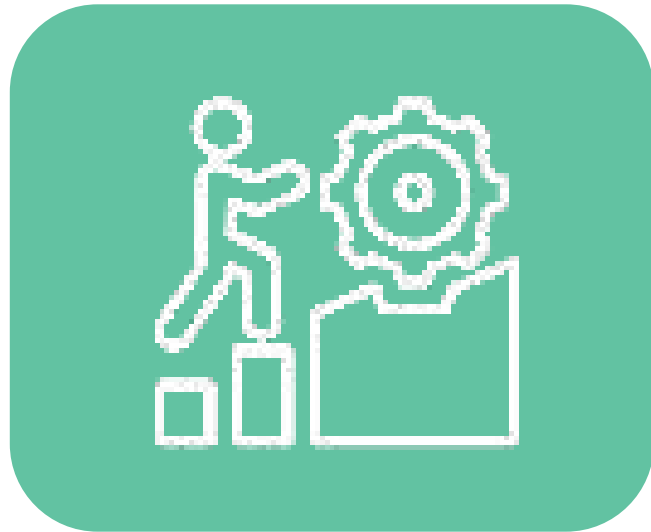

Challenges

Put your skills to the test!

Sub-topic 1: Introduction to Tinkercad online software (theoretical part)

Challenge



Hole and Ball Challenge
A 3D-printed ball and a 3D-printed hole are shown. The ball is yellow and the hole is blue. The challenge is to design a hole that fits the ball.

Hot Air Balloon Challenge
A hot air balloon is shown. The challenge is to design a hot air balloon that can float in the air.

Building a Table Challenge
A table is shown. The challenge is to design a table that is sturdy and functional.



Bear's Nest Challenge
A bear's nest is shown. The challenge is to design a bear's nest that is comfortable and functional.

Pine Trees Challenge
A row of pine trees is shown. The challenge is to design a row of pine trees that are realistic and functional.

Sub-topic 1: Introduction to Tinkercad online software (theoretical part)

Example of a model in process of creation in Tinkercad

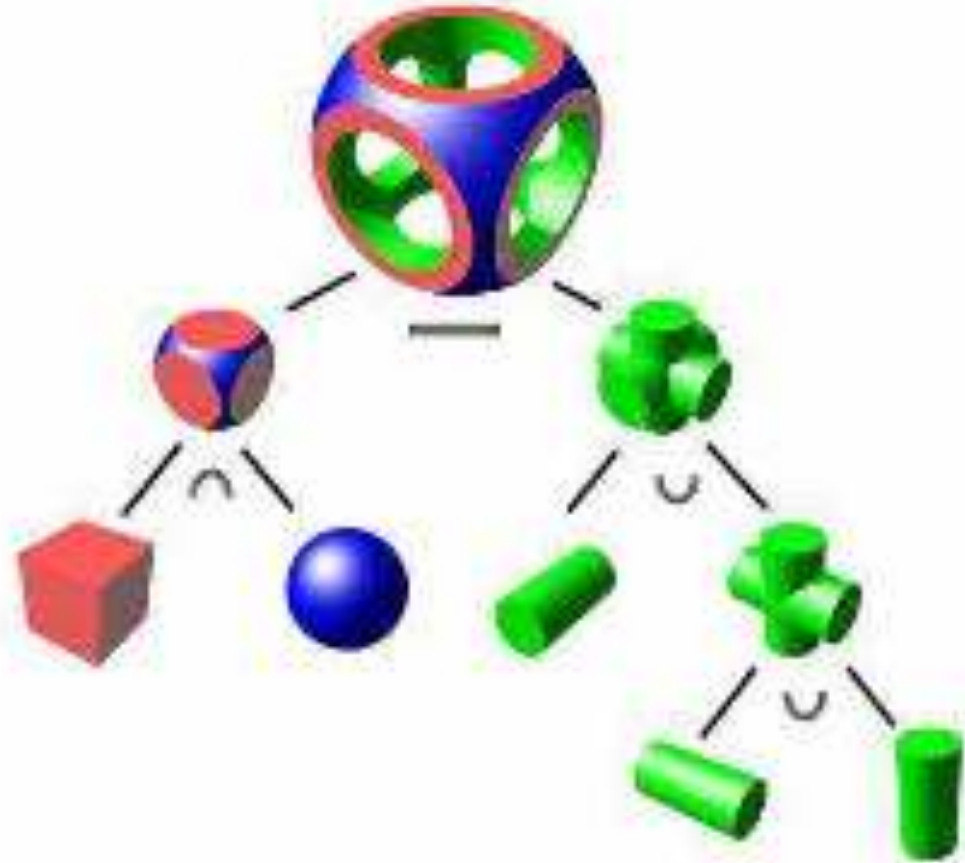

Learning outcomes

Sub-topic 2: Introduction to CURA slicing software (theoretical part)

| Module 1: 3D Technologies Topic 2 : The 3D Printing Process | | |
|--|--|---|
| KNOWLEDGE | SKILLS | ATTITUDES |
| Sub-topic 1: Introduction to CURA slicing software (theoretical part) | | |
| MOVERS | <ul style="list-style-type: none">• Introduction to the basic concepts CURA software | <ul style="list-style-type: none">• Understanding the temperature, material replacement, support during printing, and processing time.• Awareness during printing and the time process, the final result of the 3D material. |



Sub-topic 2: Introduction to CURA slicing software (theoretical part)

What is 3D curation used for?

The term "Slicing software" refers to a program suitable for transforming a CAD file into a file that can be interpreted by the 3D printer. The innovative Cura software simplifies 3D printing by making machine program creation effective and intuitive.

Cura is an open source program developed by Ultimaker that converts a 3D model into instructions that the printer uses to produce the object.



Sub-topic 2: Introduction to CURA slicing software (theoretical part)



Sub-topic 2: Introduction to CURA slicing software (theoretical part)

How to transform an stl file to Gcode with cura?

The task is quite simple: drag and drop the . stl file into the interface (or select the icon with the folder in the 3D view). The model will load on Cura.

You can select it, move it around, and control how the unit will behave layer by layer (this is a critical thing to do).



Sub-topic 2: Introduction to CURA slicing software (theoretical part)



Cura slicing software recognizes a wide range of file formats (STL, OBJ, X3D, 3MF, BMP, GIF, JPG, PNG, etc.). They differ from the file formats that are native to the CAD software used. These file formats are triangulated 3D files.

Unlike common CAD 3D files, a triangulated 3D model holds only the surface of the object and not the individual primitives and editable content. The surface of the object then consists of an accumulation of triangles whose size can vary according to the resolution chosen when converting to the triangulation format.



Sub-topic 2: Introduction to CURA slicing software (theoretical part)



A simple "Drag & Drop" action is necessary to import the 3D model to Cura slicing software. It is also possible to click on the floating folder icon on the left or select File > Open File(s) from the top menu.

Sub-topic 2: Introduction to CURA slicing software (theoretical part)

Prepare 3D file

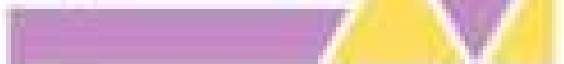

Sometimes parts need to be moved, scaled, rotated or multiplied. This is fully accessible with just a few clicks thanks to the "Tools panel".

If the 3D model needs adjustments, all we need to do is click on the 3D part and then select the option from the "Tools panel" on the left.

Depending on the selected "Tool option", specific arrows or hoops will appear around the model.

To modify the part, you can either use the arrow/hoop that appears or enter the information directly on the open panel. The change can be cancelled by clicking right on the part then on the button "Reset".

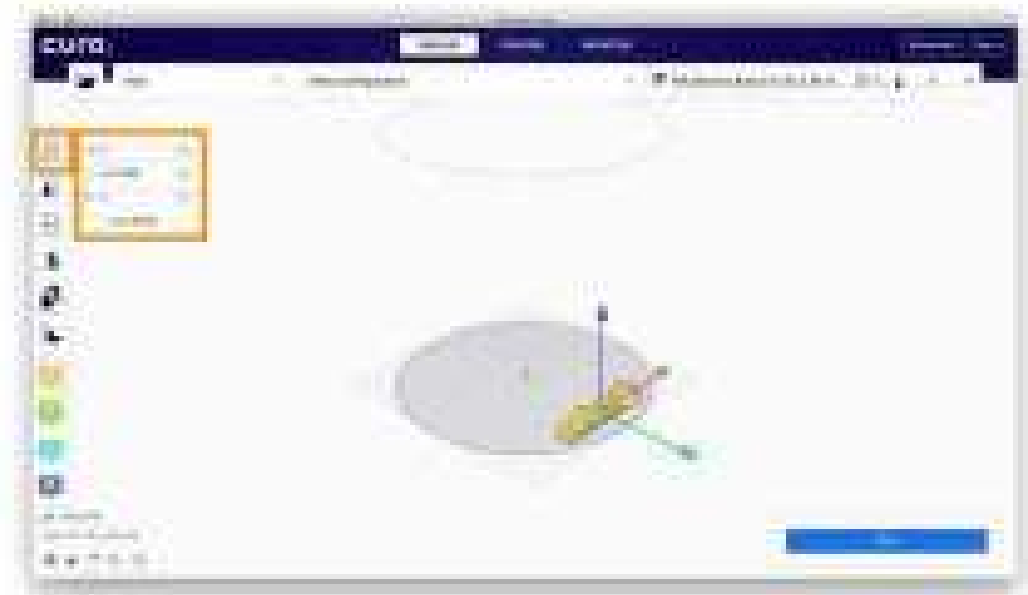

Sub-topic 2: Introduction to CURA slicing software (theoretical part)



Example of a 3D model
scale with the slicing
software.

Sub-topic 2: Introduction to CURA slicing software (theoretical part)



Example of a 3D model rotation with the slicing software.

Sub-topic 2: Introduction to CURA slicing software (theoretical part)



The slicing "Settings panel" is divided into two sections, one dedicated to the 3D printer settings and the other to the printing settings.

The top section of the slicing software is dedicated to the 3D printer settings and the right section to the printing settings.

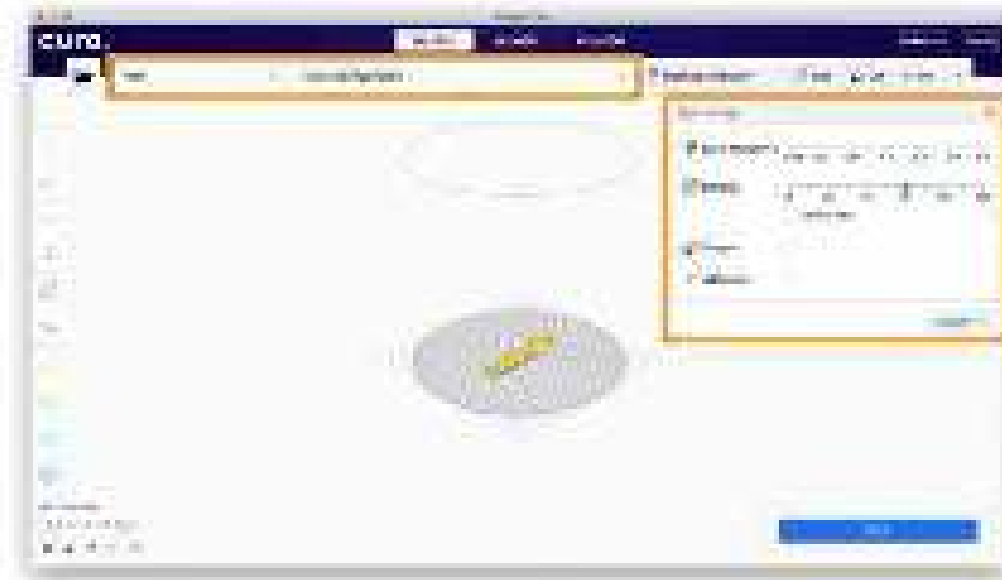

Sub-topic 2: Introduction to CURA slicing software (theoretical part)

Printer settings

This section allows the user to select the right 3D printer and its configuration (nozzle specifications).



Sub-topic 2: Introduction to CURA slicing software (theoretical part)

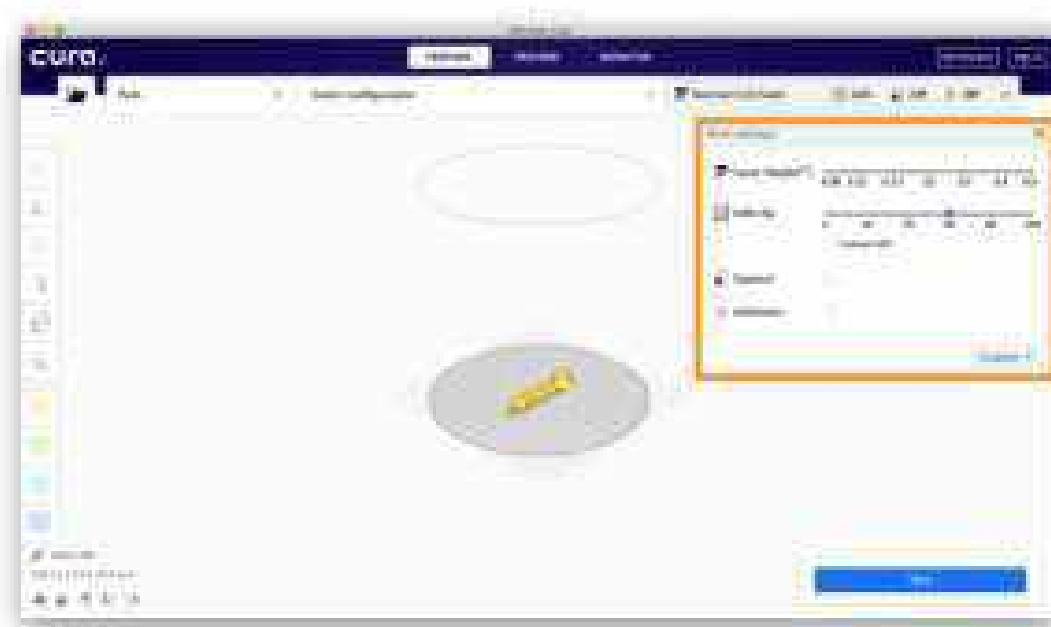

Sub-topic 2: Introduction to CURA slicing software (theoretical part)

Slice, visualize

& export

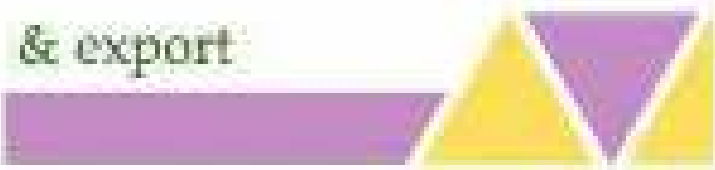

The slicing procedure consists in interpreting the 3D file in a series of 2D plans according to the selected 3D printing parameters. This step will result in a digital interpretation that can be viewed in the slicing software. Once validated, it can also be assessed in a G-code file.

Sub-topic 2: Introduction to CURA slicing software (theoretical part)

Slicing

An accessible button is present to allow the slicing procedure, by clicking it. The "slicing" button launches the analysis and interpretation process.



Sub-topic 2: Introduction to CURA slicing software (theoretical part)

Selecting your 3D Printer

Select the 3D printer. If further 3D printers are installed, it will be necessary to select the right one from the drop-down menu.

Configuration: Quickly select the mounted nozzle per each extruder.

Print settings

There are three basic ways to view the model:

- Solid
- X-Ray
- Layers

Sub-topic 2: Introduction to CURA slicing software (theoretical part)

Solid visualization: this is the default view that enables to have a global vision of the part, size, printing orientation, etc.
Using the navigation settings to change the viewpoint can also be useful.



Sub-topic 2: Introduction to CURA slicing software (theoretical part)



Sub-topic 2: Introduction to CURA slicing software (theoretical part)

X-Ray visualization: available under the preview settings, this function allows analysing the internal structure of the 3D part, and to understand which part element needs to be reworked.

Using the navigation settings to change the viewpoint can also be useful.



Sub-topic 2: Introduction to CURA slicing software (theoretical part)



Sub-topic 2: Introduction to CURA slicing software (theoretical part)

What type of file is an STL?

STL is a format commonly used for 3D printing and computer-aided design (CAD). The name STL stands for stereolithography, a well-known 3D printing technology, but you might sometimes find it also referred to as Standard Triangle Language or Standard Tessellation Language.

Each file consists of a series of connected triangles that describe the surface geometry of a 3D object or model. The more complex the design, the more triangles are used and the higher the resolution.

You can recognize an STL image by the .stl file extension and the lack of color and texture.



Sub-topic 2: Introduction to CURA slicing software (theoretical part)

History of the STL file.

The STL format was created by 3D Systems in 1987 as part of the development of stereolithographic printing technology for commercial 3D printers. The process used a computer-controlled laser beam and pre-programmed CAD software to create 3D models for rapid prototyping.

The STL file format hasn't changed much since then and is currently considered the standard for 3D printing. It still uses triangular tessellation to create the geometric surface of an object, storing the details of each triangle, such as the coordinates of each individual vertex.



Sub-topic 2: Introduction to CURA slicing software (theoretical part)

What are STL files for?

The STL format is known for its ability to convey the geometric composition of a 3D drawing and bring CAD designs to life. Let's look at some of the most common uses of STL files.

3D printing

3D printing is a form of additive manufacturing (AM): a flexible approach to industrial manufacturing. 3D designs are printed in layers to form lighter, stronger parts using STL files and CAD software.

Rapid prototyping

STLs were originally designed to speed the creation of scale models for rapid prototyping. This means that an STL file is used to design a product or component and then printed to test the product in different scenarios before finalizing the design.



Sub-topic 2: Introduction to CURA slicing software (theoretical part)

Pros and cons of STL files

Using the STL format can be very advantageous, but there are some downsides that are important to know, because it may not always be the format best suited to your needs. Read on to learn more about the advantages and disadvantages of STLs.



Sub-topic 2: Introduction to CURA slicing software (theoretical part)

Advantages of STL files

- Almost all 3D printers are capable of using and supporting STL files. As an almost universally recognized format, it is a reliable choice for designing and printing 3D objects or models.
- STL files can be used to create a wide variety of objects, from lamps and vases to drone accessories and camera tripods. Whichever shape you choose, it can usually produce an accurate model.
- STLs do not contain colors and textures, so they tend to be smaller in size and still provide faster processing times than other file types. For this reason, the STL format is a smart choice for printing objects of a single color and material.



Sub-topic 2: Introduction to CURA slicing software (theoretical part)

Disadvantages of STL files

- STLs are great for printing complex shapes, but have relatively limited capabilities for other aspects, including color and texture. For this reason they are mainly used for prototyping, rather than for the final product.
- Another disadvantage of STLs is that they cannot store metadata, i.e. details such as author, copyright and location, all of which are essential for publishing.

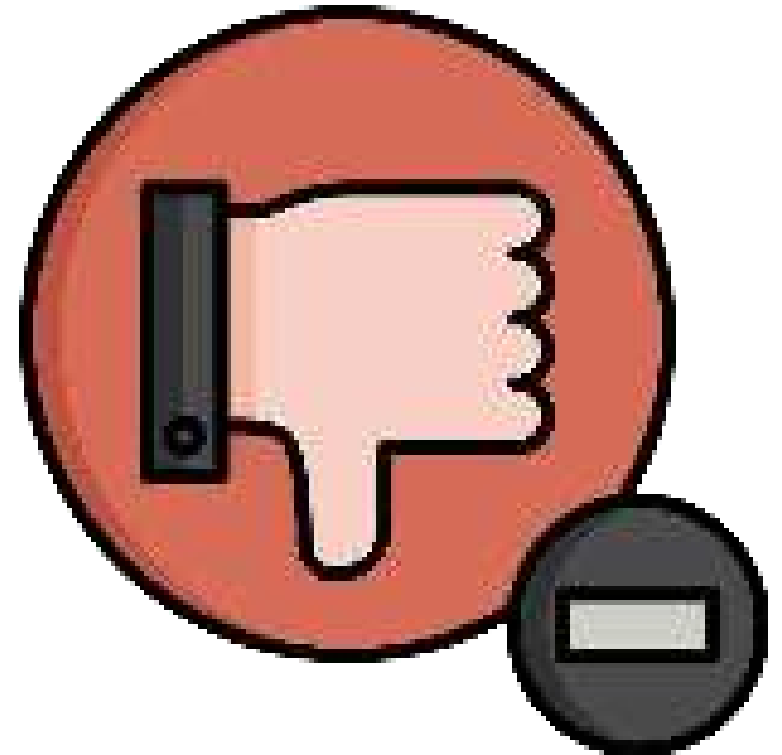

Sub-topic 2: Introduction to CURA slicing software (theoretical part)

Disadvantages of STL files

- STLs are great for printing complex shapes, but have relatively limited capabilities for other aspects, including color and texture. For this reason they are mainly used for prototyping, rather than for the final product.
- Another disadvantage of STLs is that they cannot store metadata, i.e. details such as author, copyright and location, all of which are essential for publishing.

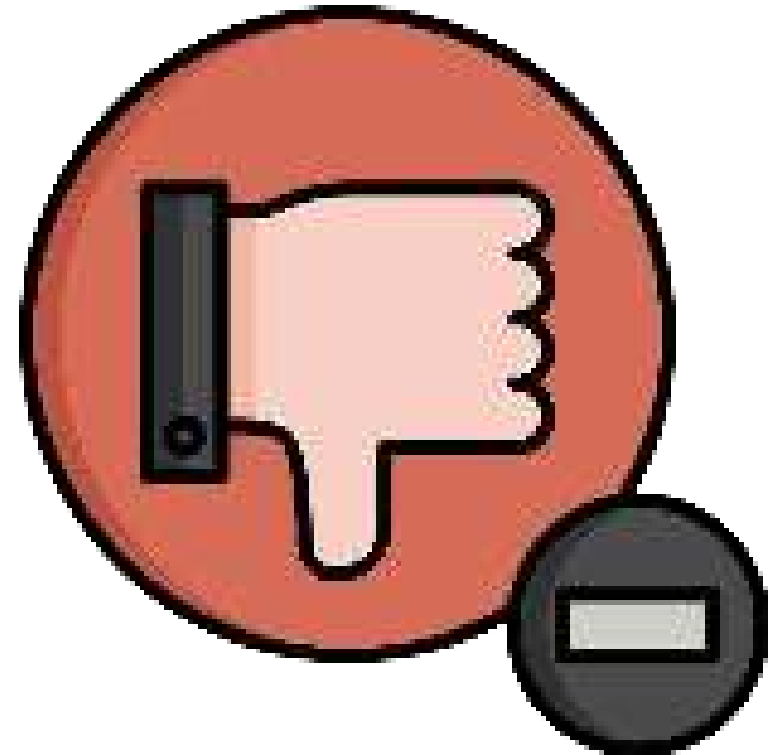

Sub-topic 2: Introduction to CURA slicing software (theoretical part)

COMPLETE PROCESS OF 3D PRINTING

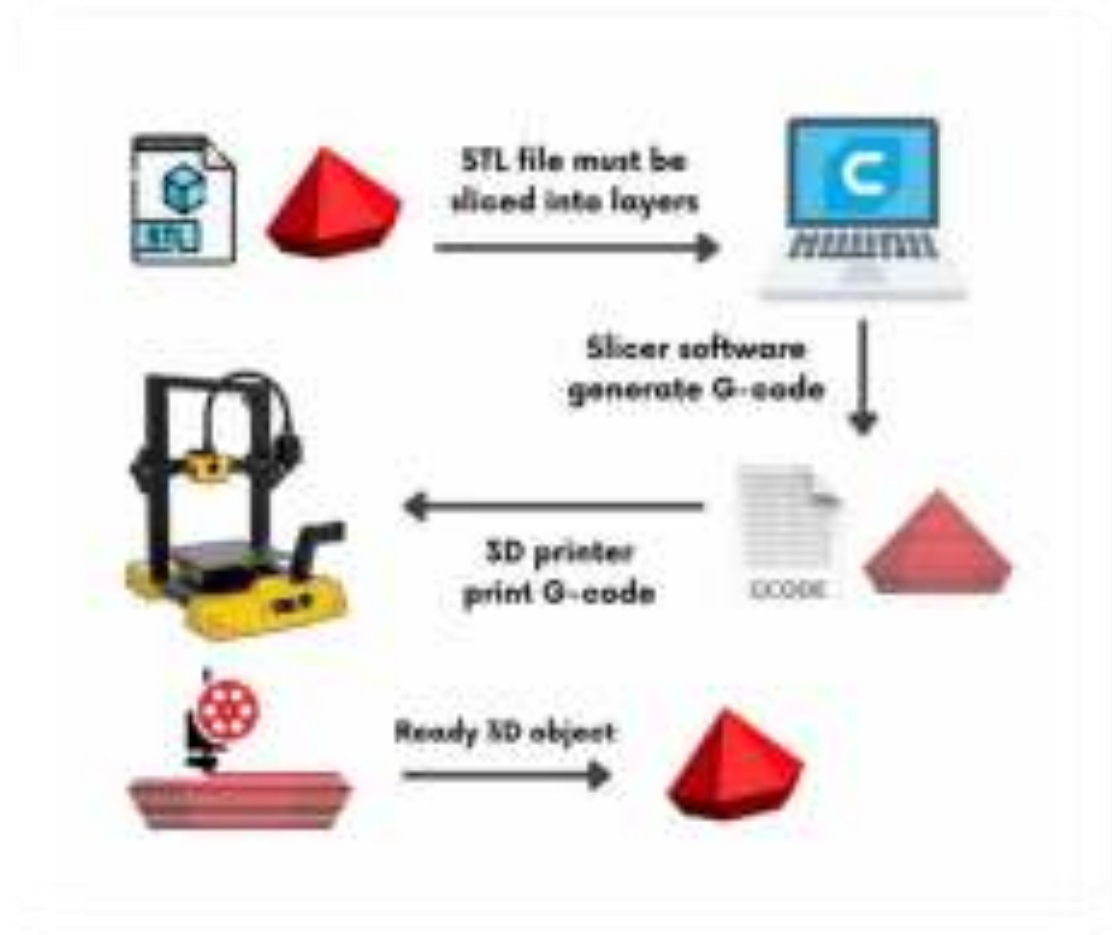

Sub-topic 2: Introduction to CURA slicing software (theoretical part)

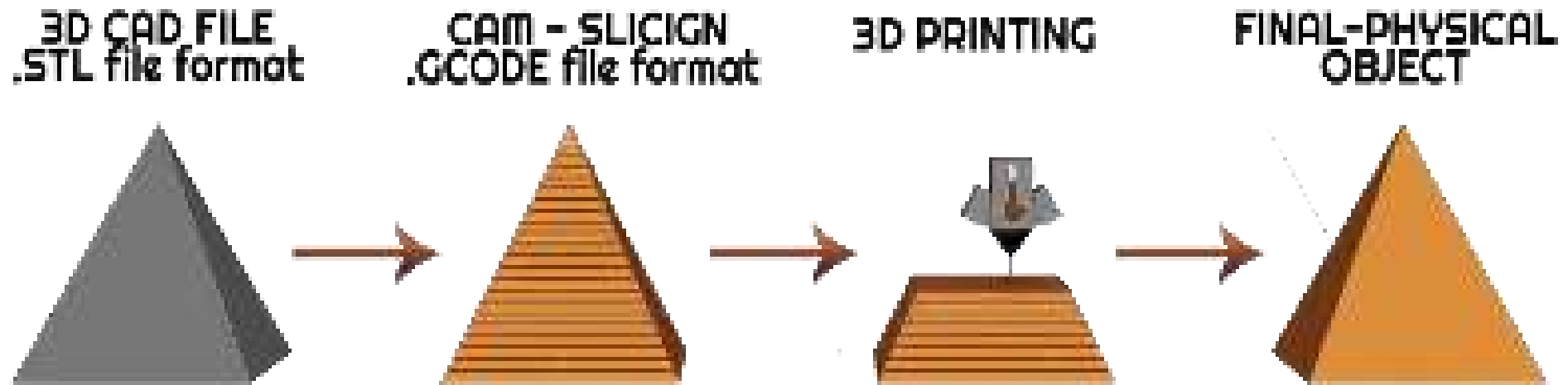

STL file must be sliced into layers, these layers represent G-code.
A printer can only read G-code file.

Sub-topic 2: Introduction to CURA slicing software (theoretical part)

How do I find the correct printing temperature for a filament?

Slicing software provides preset profiles for common materials such as PLA and PETG, but we know that each printer has its own calibrations, so we need to adjust the parameters slightly to our needs.

Find the PERFECT filament TEMPERATURE



Sub-topic 2: Introduction to CURA slicing software (theoretical part)

The temperatures of materials

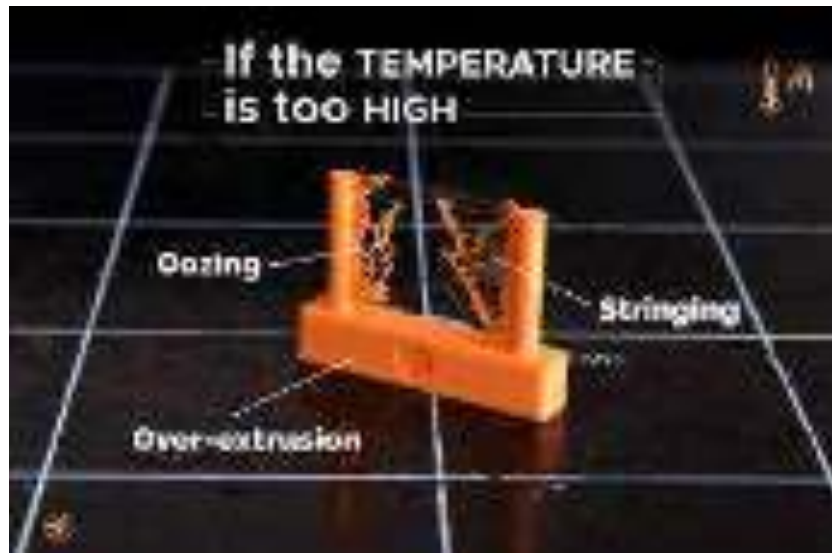

Sub-topic 2: Introduction to CURA slicing software (theoretical part)

How do you measure temperature?

FILIALFA® provides its customers with the ideal temperature range for each material both in the filament tab on the website and on the spool and box labels. To find the nozzle temperature for your printer, we always recommend starting at the highest temperature listed and going down 5° at a time until you get the perfect print.

There are two ways to do this test: manually lower the temperature when printing a test file, or use a Temp Tower. This kind of printing makes it easy to compare the behavior of a filament at different temperatures.

Just set from the slicer the temperature change to the corresponding height in the file.



Sub-topic 2: Introduction to CURA slicing software (theoretical part)

High temperature

High temperatures allow faster melting of the filament, resulting in a decrease in its viscosity, making it easier for the material to exit the nozzle.

This allows better adhesion between layers, making the object stronger at the expense of outer wall definition.

With higher printing temperatures, in fact, it is more difficult to control the flow, resulting in increased over-extrusion, stringing and oozing.

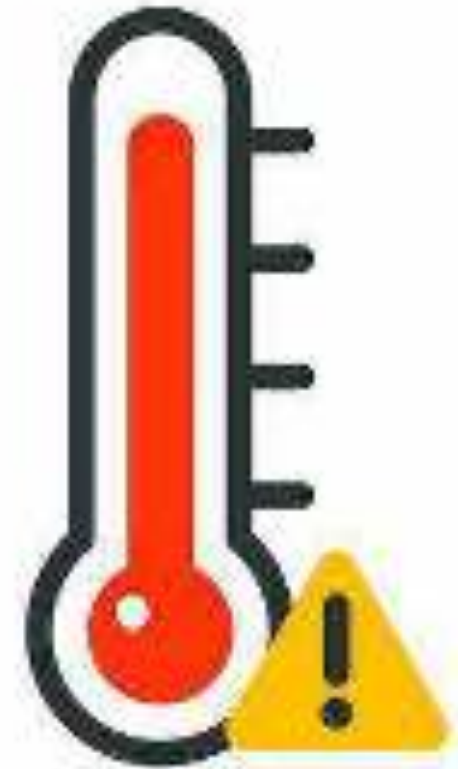

Sub-topic 2: Introduction to CURA slicing software (theoretical part)

Low Temperature

Lower temperatures can be an ally if you want to improve the definition of the printed object, but if you are too far from the ideal temperature, problems of under-extrusion can arise, up to and including filament clamping inside the nozzle (clogging).

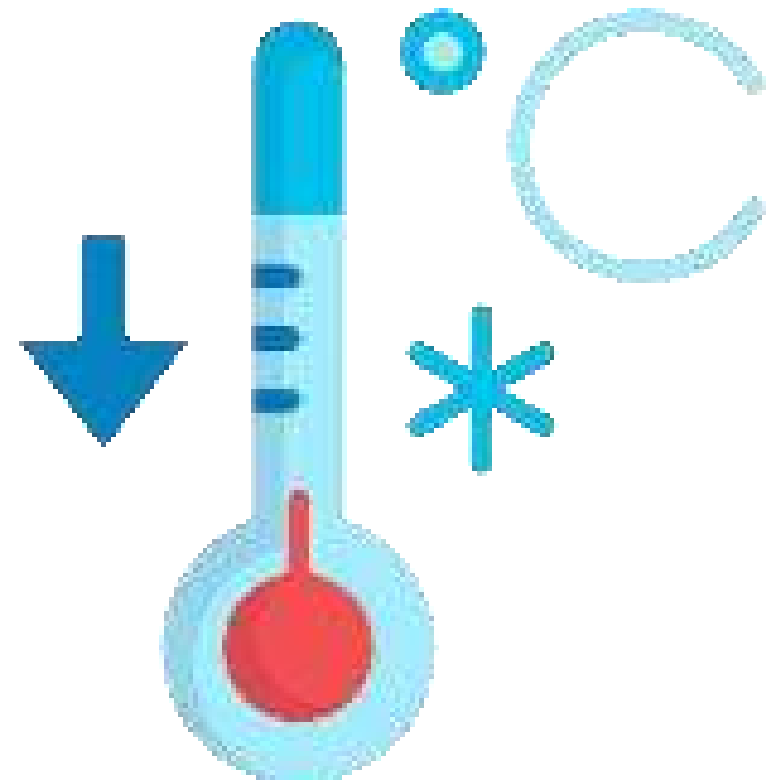

Sub-topic 2: Introduction to CURA slicing software (theoretical part)

The temperature of the printing plane

In the printing of a material, a key role is also played by the printing plane: its correct temperature allows first of all to avoid adhesion and warping problems, but also other phenomena, such as elephant foot, the subject of other articles in this Academy.



Sub-topic 2: Introduction to CURA slicing software (theoretical part)

The ideal printing temperatures

PLA

PLA is an easy material to print because it adapts to different printing temperatures: it can be successfully extruded from 180 to 220° and even beyond. In FILOALFA® we recommend setting the nozzle at 200-205°C, the printing plate at 40-50° or even cold if your printer does not have this feature. PLA also tolerates cooling well, allowing the filament to "freeze" in place in case of undercuts and bridges.

PETG

The temperature range for PETG is 230° to 250°C, while it is advisable, but not essential, to heat the printing plate to 60-70°. Ventilation can be kept on if special finishing is needed. Printing PETG is almost as simple as printing PLA, however, one must set the retractions correctly as this material tends to do stringing.

NYLON

It requires high temperatures and care in printing because of its tendency to shrink. As with ABS, it is best to use a closed chamber to avoid abrupt cooling; we recommend a temperature between 210 and 240°C for the nozzle with the fan off, and a hot plate between 60-80°C.

ABS

FILOALFA® ABS needs higher temperatures ranging from 240° to 290°, with the top at 70°-110°. ABS needs to cool very slowly, or it will tend to shrink, so we recommend keeping cooling fans off and printing in a closed chamber.

FILOFLEX

The parameters of TPU-based flexible materials are similar to those of PLA, with an ideal temperature around 210°C. However, when printing flexible materials, it is critical to lower the printing speed a lot and to greatly reduce, if not eliminate altogether, retractions to prevent the filament from jamming after the extruder knurling wheel.

Learning outcomes

Sub-topic 3: Preparation of 3D Printer

| Module 1: 3D Technologies Topic 2 : The 3D Printing Process | | |
|--|---|---|
| KNOWLEDGE | SKILLS | ATTITUDES |
| Sub-topic 3: Preparation of 3D Printer | | |
| MOVERS | <ul style="list-style-type: none">The participants need to be familiar with the types of materials used in the 3D printing process. | <ul style="list-style-type: none">Understanding the types of materials and how they could be used based on needs, as well as managing material space in the 3D printer.Understanding the printer temperature, the use of materials for finalization, and the requirements. |



Sub-topic 3: Preparation of 3D Printer

3D Printing Processes & 3D Printer Components

Different 3D Printing Processes

Technically, the term "3D printing" refers to the development of any three-dimensional object layer by layer using a design created on a computer. The procedures used in this type of additive manufacturing are diverse and vary depending on the methods and materials used during the development of the product.

However, regardless of the process used, the idea behind of creating objects with 3D printing technology remains the same, starting starting from the production of a 3D model with the help of software of computer-aided design (CAD) to the commissioning of the machine.

However, as discussed below, the actual technical process used to create the physical object varies.



Sub-topic 3: Preparation of 3D Printer

There are four different types of 3D printing processes you are likely to encounter:

- ✓ Fused Deposition Modelling (FDM)
- ✓ Stereolithography (SLA)
- ✓ Selective Laser Sintering (SLS)



Sub-topic 3: Preparation of 3D Printer

3D Printing Technologies for Plastics

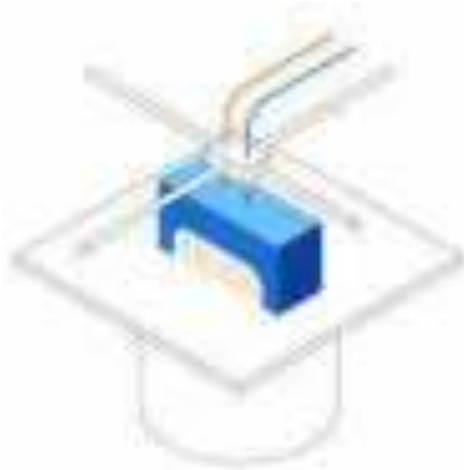

FDM

Fused Deposition Modeling

- Melts and extrudes thermoplastic filament
- Lowest price of entry and materials
- Lowest resolution and accuracy

BEST FOR

Basic proof-of-concept models and simple prototyping

Sub-topic 3: Preparation of 3D Printer

Fused Deposition Modeling (FDM)

Fused Deposition Modeling (FDM) is the process of 3D printing most widely known. It is a technique bottom-up based on melting the filament and deposition on a table, layer by layer, according to the sliced pattern.

FDM mainly uses materials plastic-based, such as polylactide (PLA) or the acrylonitrile butadiene styrene copolymer (ABS).

The fused deposition printing process is a manufacturing technology additive used for modeling, prototyping and manufacturing applications. This method also works by creating an object layer by layer.

However, there are some differences in the way materials are used by this technology.

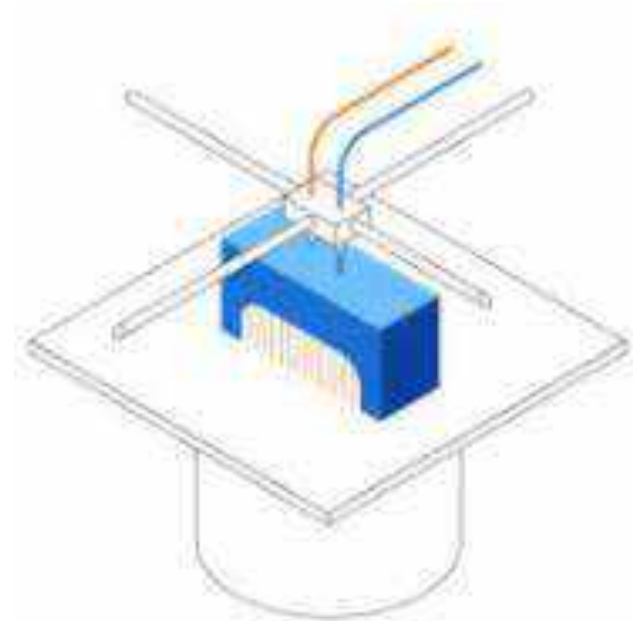

Sub-topic 3: Preparation of 3D Printer

How it works

3D printers using FDM technology build an object layer layer by layer by heating a thermoplastic material in a semi-liquid state.

To complete the print, FDM uses two materials: a modeling material and a support material. The former forms the final product, while the second serves as the scaffold.

The raw materials are supplied from the printer housings, and the printer head is designed to move according to X and Y coordinates, controlled by the computer. It moves vertically (Z axis) only when a layer has been completed.

The advantages offered by FDM make it suitable for use in offices, as it is a clean and easy-to-use method.

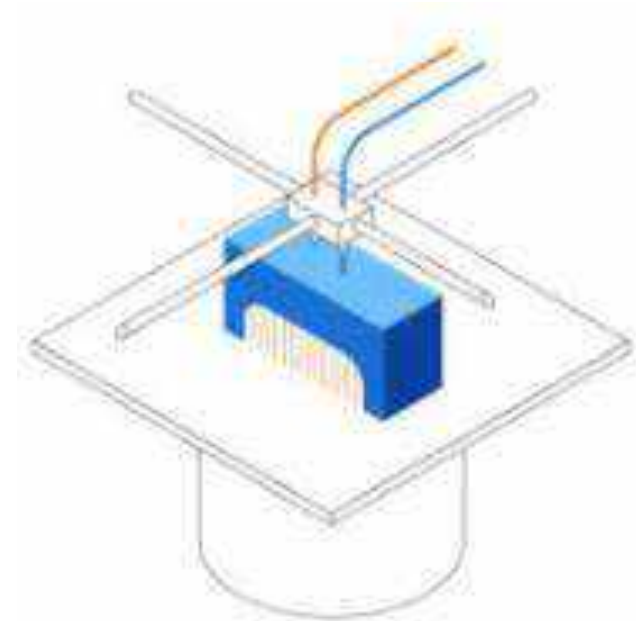

Sub-topic 3: Preparation of 3D Printer

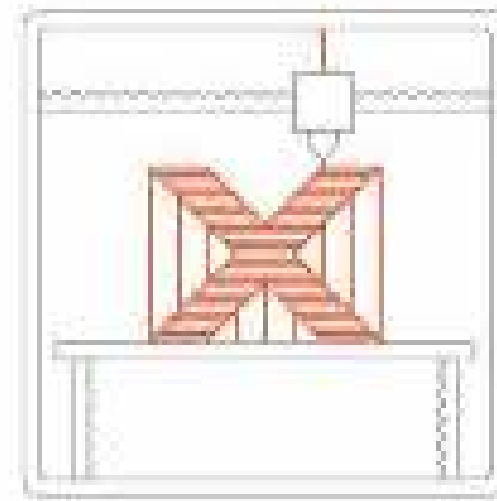
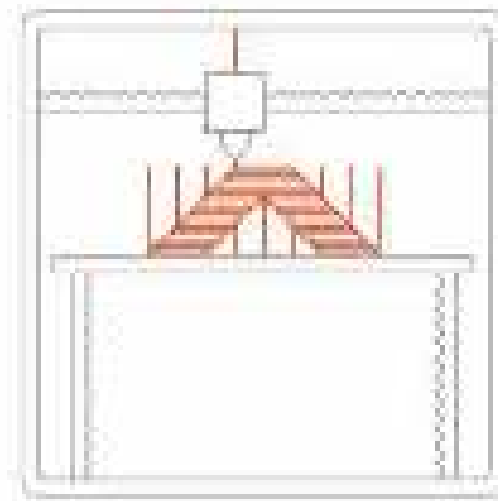
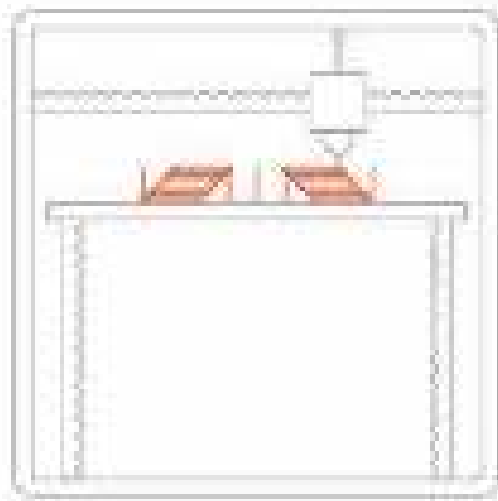

Sub-topic 3: Preparation of 3D Printer

3D Printing Technologies for Plastics

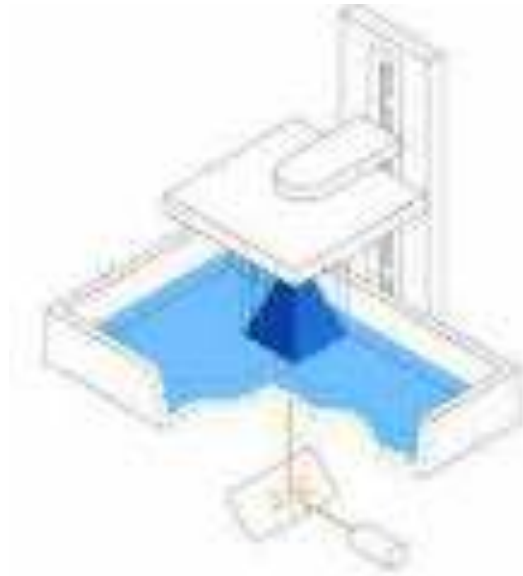

SLA Stereolithography

- Laser cures photopolymer resin
- Highly versatile material selection
- Highest resolution and accuracy, fine details

BEST FOR:

Functional prototyping, patterns, molds and tools

Sub-topic 3: Preparation of 3D Printer

Stereolithography (SLA)

SLA has the historical merit of being the first 3D printing technology in the world.

The stereolithography was invented by Chuck Hull in 1986, who filed a patent on this technology and founded the company 3D Systems to commercialize it.

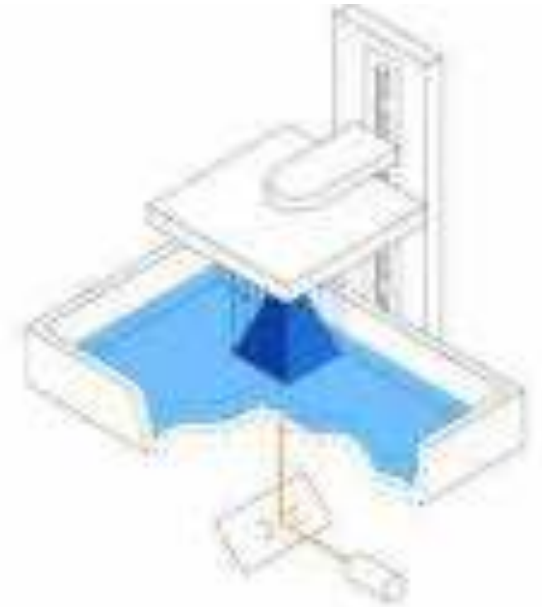

Sub-topic 3: Preparation of 3D Printer

How it works

An SLA 3D printer starts with an excess of liquid plastic.
A portion of this plastic is cured (or hardened) to form a 3D object.

There are four main parts in an SLA printer:

- A printer filled with liquid plastic
- A perforated platform
- A UV laser
- A computer that controls both the laser and the platform

To begin with, a thin layer of plastic (between 0.05 and 0.15 mm) is exposed over the platform. The laser "draws" the model of the object on the platform, as indicated in the design files. As soon as the laser touches the material, it hardens. This process continues until the entire object.

Objects created with the SLA are generally smooth, while the quality of the object depends on the complexity of the SLA machine.

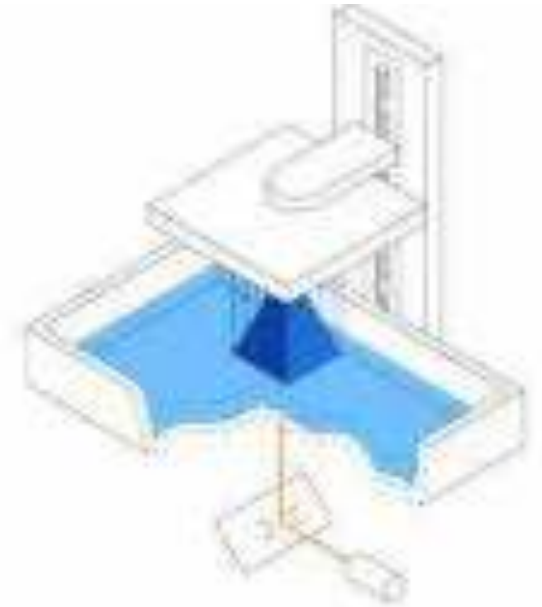

Sub-topic 3: Preparation of 3D Printer

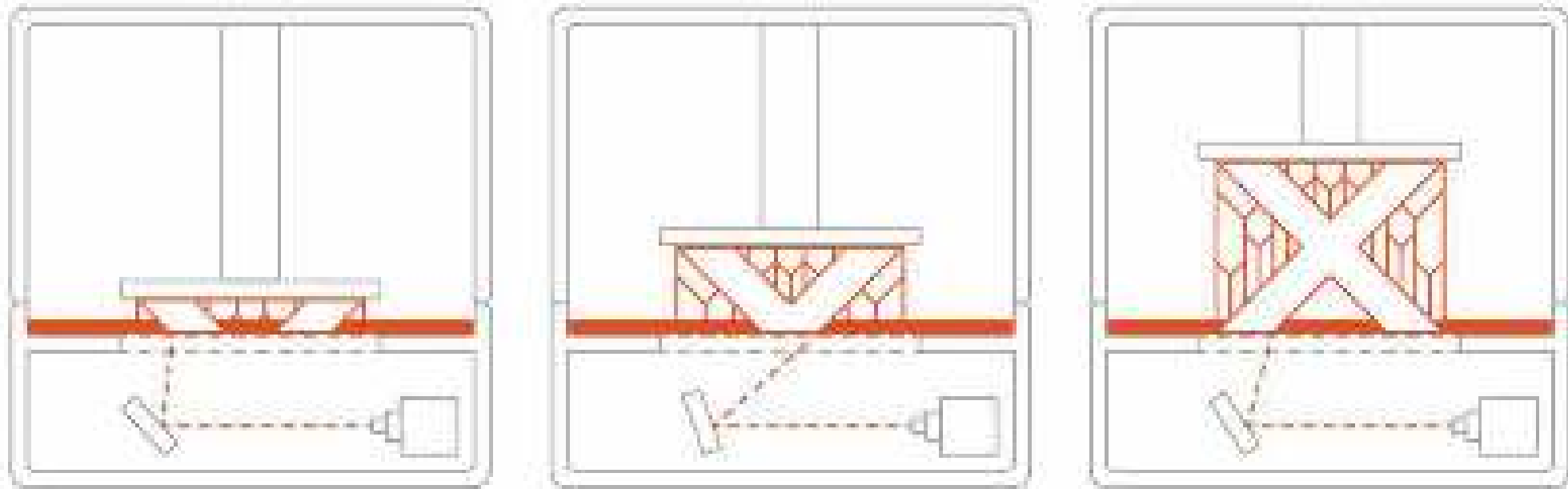

Sub-topic 3: Preparation of 3D Printer

3D Printing Technologies for Plastics



The diagram illustrates the SLS process. A laser beam is directed at a powder bed, sintering the particles together. A recoater blade then moves across the surface to level the powder for the next layer. The process is shown in a cross-sectional view, highlighting the layer-by-layer construction of the part.

SLS
Selective Laser Sintering

- Laser fuses polymer powder
- Low cost per part, high productivity, and no support structures
- Excellent mechanical properties resembling injection-molded parts

BEST FOR
Functional prototyping and end-use production

Sub-topic 3: Preparation of 3D Printer

Selective Laser Sintering (SLS)

SLS is one of the most widely used 3D printing technologies. During the process of SLS printing, tiny particles of ceramic, glass or plastic are fused together by a high-power laser.

The heat of the laser fuses these particles to form 3-D objects.

Carl Deckard, an undergraduate student at the University of Texas, along with his professor Joe Beaman, has developed and patented this process in the 1980s.

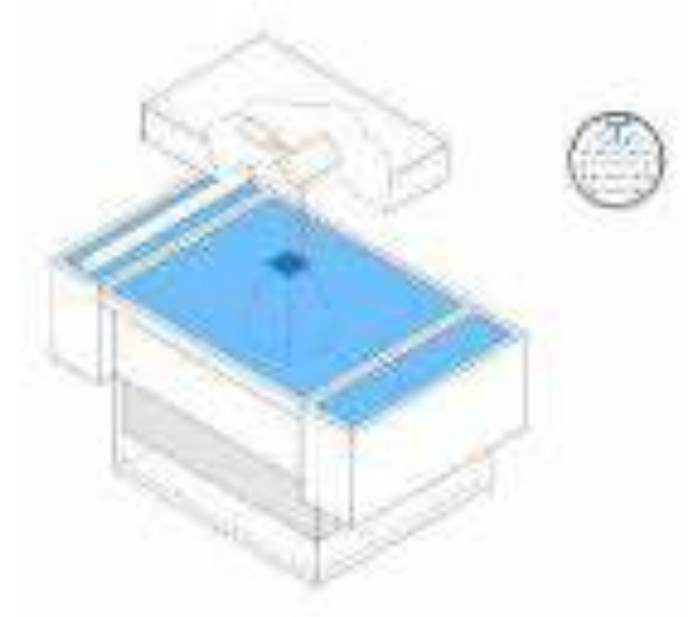

Sub-topic 3: Preparation of 3D Printer

How it works

Like all other 3D printing processes, the process of creating an object with an SLS machine begins with the design of a 3D model using a CAD software. These files are then converted to .STL, which is recognizable by the 3D printers.

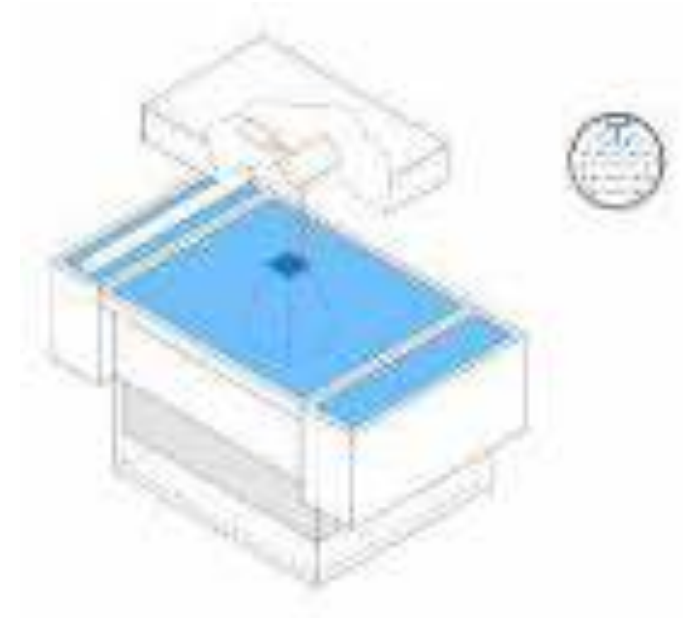

Sub-topic 3: Preparation of 3D Printer

Parts of a 3D printer

If you are a beginner who wants to start 3D printing, your first 3D printer will most likely be an FDM printer. The easiest way easy way to understand how FDM works is to learn about its components.

Before we talk about the specific components, however, it's good to remember that most 3D printers use three axes: X, Y, and Z.

The X and Y axes are responsible for horizontal movements to the left and right, forward and backward, while the Z axis handles the movements vertical.

Sub-topic 3: Preparation of 3D Printer

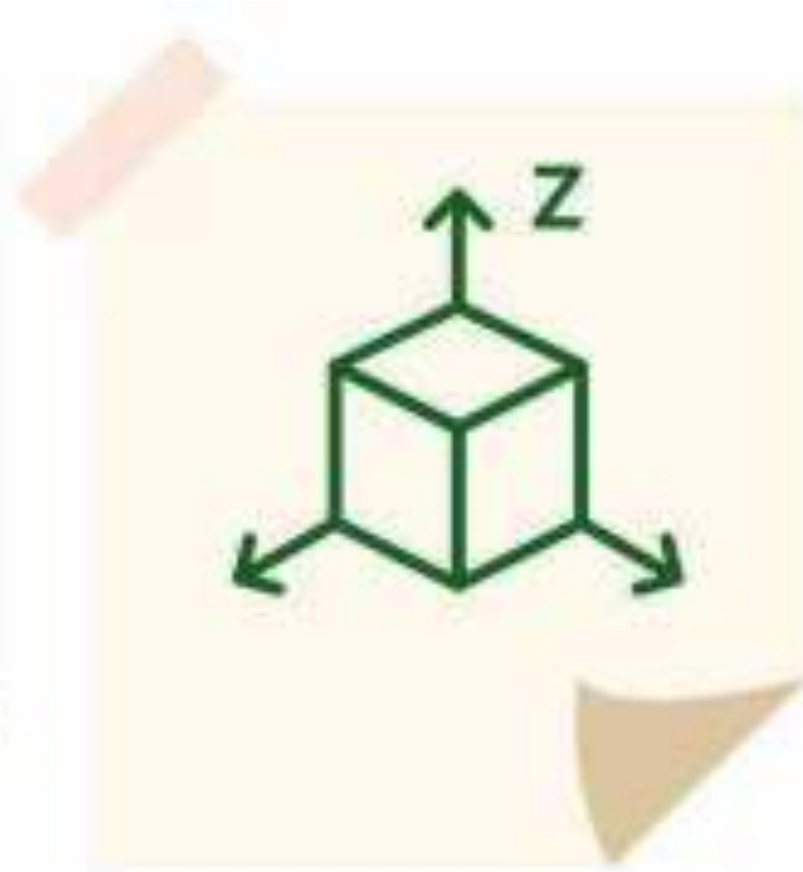
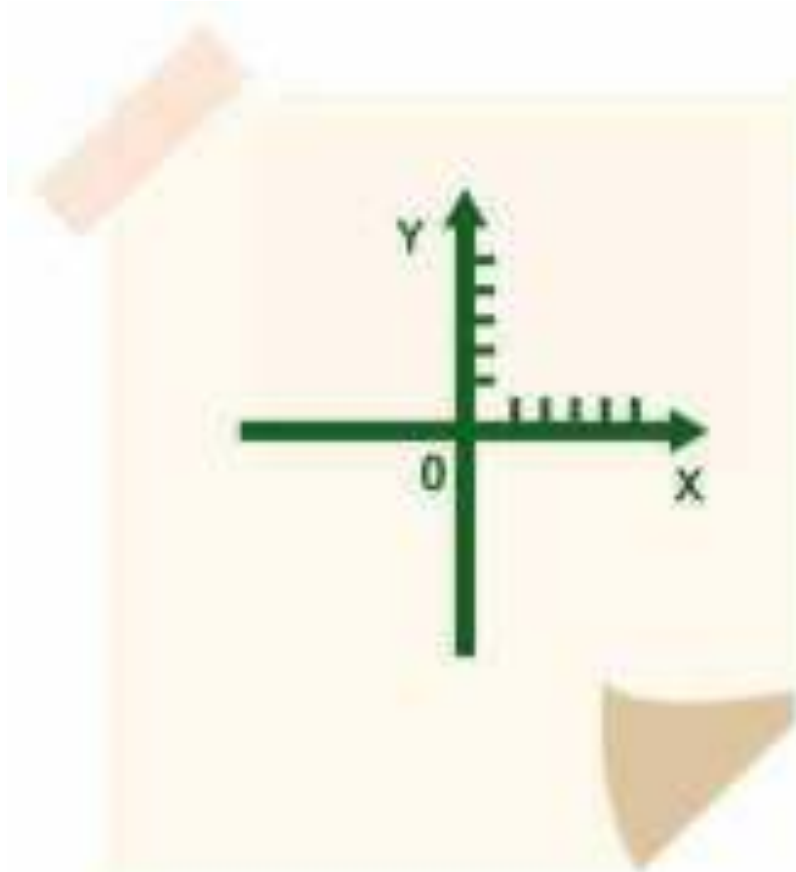

Sub-topic 3: Preparation of 3D Printer

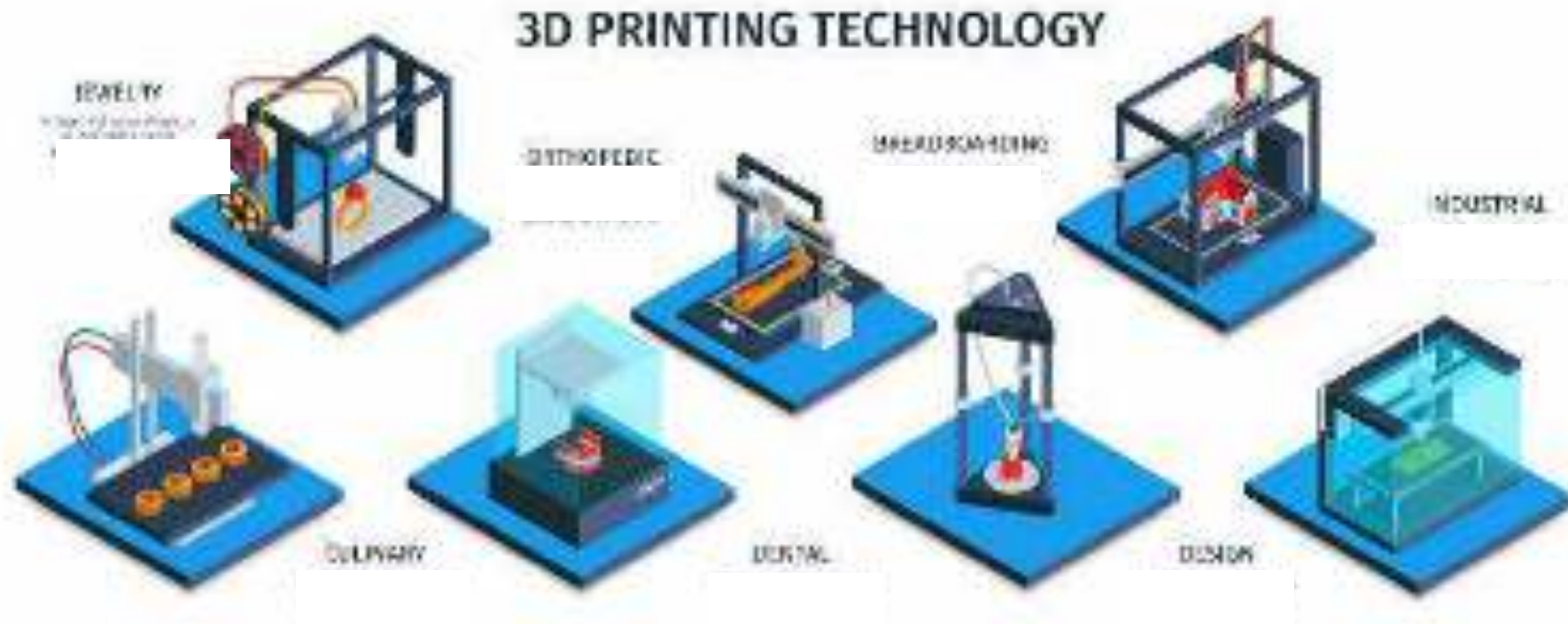

Sub-topic 3: Preparation of 3D Printer

The main components of a 3D printer

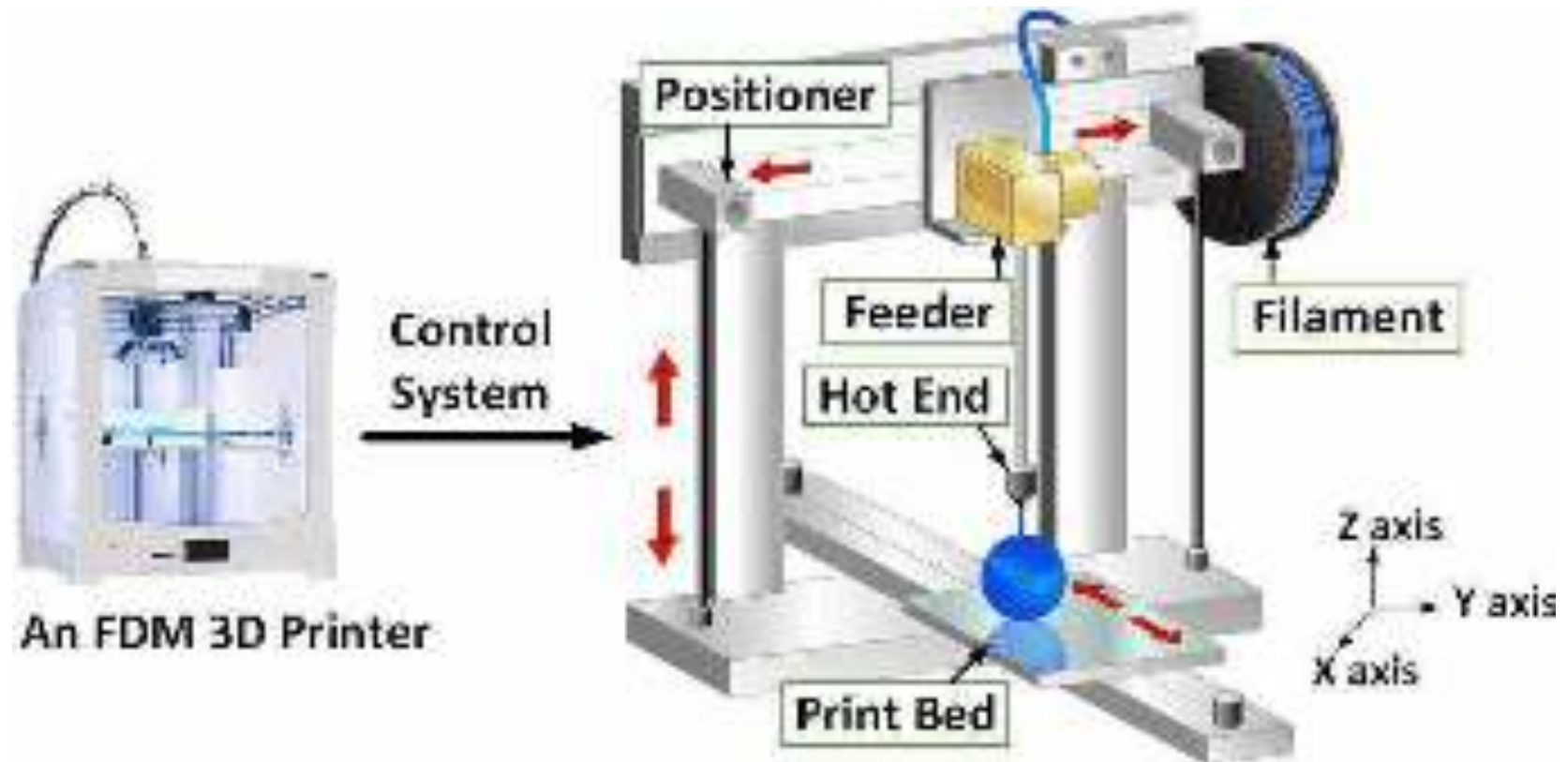

Sub-topic 3: Preparation of 3D Printer

Nozzle (connected to the extruder)

Nozzle diameters have an impact on several aspects of printing, including the accuracy and speed.

When choosing a nozzle, the goal is to balance speed and accuracy.

| Larger nozzles (>0.4 mm) | Smaller nozzles (<0.4mm) |
|---|-------------------------------|
| ✓ Time to faster fast | ✓ High accuracy |
| ✓ Less maintenance/ errors related to nozzles | ✓ More maintenance - clogging |



Sub-topic 3: Preparation of 3D Printer

Extruder

The extruder is one of the most important parts of the printer. Also known as the cold end, it has the task of guiding and leading the filament from the spool to the hotend for melting.

The extruder is the upper part of the extruder. Its job is to transport and push the filament into the lower part of the assembly, the hot end.



Sub-topic 3: Preparation of 3D Printer

Hotend

The hotend is another essential part of the 3D printer. It is the part that melts, extrudes and deposits the filament onto the printer bed for printing.

After the extruder feeds the filament into the hotend, the filament passes through a heated path called the melting zone.

Here the filament melts due to heat.

Due to the pressure of the extruder, it is pushed out of the small nozzle opening.



Sub-topic 3: Preparation of 3D Printer

Cooling (Parts cooling fans)

Part cooling fans cool the hot plastic that has just been extruded from the nozzle.

This eliminates various types of printing problems. However, some materials, such as ABS, create more problems with the fan for cooling of the parts activated.

Therefore, it is recommended always check whether the cooling fan is necessary for different materials.

For most most filaments, such as PLA, it is recommended to use a cooling fan.



Sub-topic 3: Preparation of 3D Printer

Construction surface / Print bed

The build surface of the 3D printer refers to the platform on which the filament is used to form the print. Depending on the printer model, the build surface can be stationary or move in a direction specific direction.

In 3D printing, the quality of the print is strongly influenced by the first layer and the adhesion of the build surface. Therefore, the build surface plays a large role in the printing process.

Depending on the type of filament material, there are different aspects to consider when using a bed of printing.

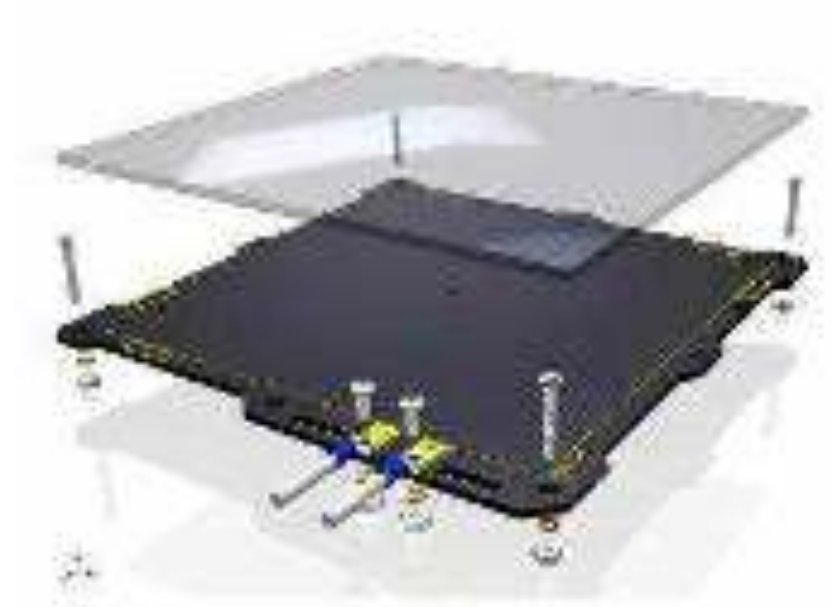

Sub-topic 3: Preparation of 3D Printer

These elements include:

✓ **Heating:** Some printing beds are equipped with a heating pad heating pad to increase the temperature of the build surface.

The increase in temperature promotes adhesion of the first layer and the deformation.

✓ **Material:** The material of the build surface also determines its its performance.

It determines the resistance of the build surface to heat and the ability of the filament to adhere to it.

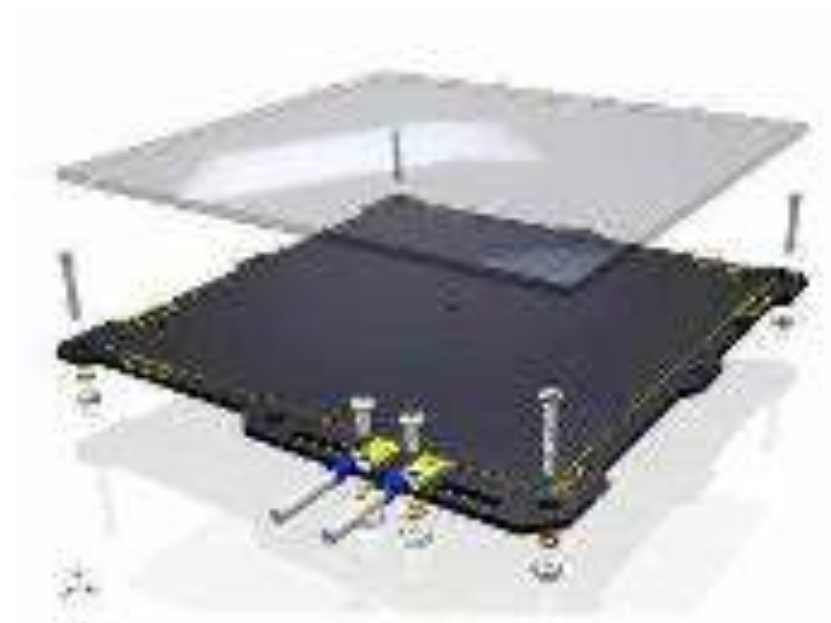

Sub-topic 3: Preparation of 3D Printer



If your extruder is too hot, you'll get more strings of melted filament from the nozzle, and this could even lead to constant leaking of the filament onto your design.

If your extruder is too cold, you could find that the printed layers just don't stick together very well, and you'll find that you need to unclog the nozzle often.

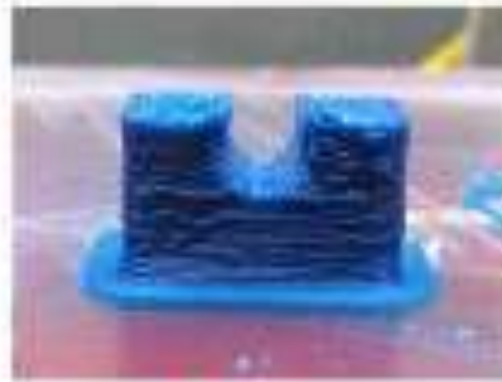

Overly hot extruder



Overly cold extruder

Sub-topic 3: Preparation of 3D Printer

Print view

The print display (or control box) is the interface human-machine interface of the 3D printer.

It is the way in which the printer operator communicates directly with the 3D printer without using a PC or other device.

Using the control box, the operator can start, pause or stop printing.

He can also upload print files from external media such as a USB flash drive or SD card. Everything depends on the type of firmware loaded on the printer.

The interface of the control unit can be a touchscreen or a simple LCD with physical buttons or a knob for control.

The interface of the control unit can be a touchscreen or a simple LCD with physical buttons or a control knob.

Sub-topic 3: Preparation of 3D Printer



Sub-topic 3: Preparation of 3D Printer

The process begins when you send a 3D model file to the printer.

The file contains a set of instructions for everything, including the temperatures at which to maintain the nozzle and build platform, as well as how to moving the nozzle and the amount of filament to be extruded.

1. When the print job starts, the nozzle heats up.
2. When the nozzle reaches the temperature needed to melt the filament, the extruder pushes the filament into the hot end. At this point, the printer is ready to start 3D printing the part.
3. The print head lowers and begins depositing the melted filament, squeezing the first layer between the nozzle and the build surface.
4. e 5. The material cools and begins to harden shortly after leaving the nozzle, thanks to the part's cooling fan(s). Once the layer is complete, the print head moves slightly upward along the Z axis and the process is repeated until the part is complete.

Sub-topic 3: Preparation of 3D Printer



Sub-topic 3: Preparation of 3D Printer



Support Removal

Support removal is the most basic form of post-processing. Usually, support removal is done by hand with effect, which leaves the supports in tact if priority of safety is a high priority.

Regularly, all 3D printed parts are supported by a support structure. After printing, they can be easily removed from the 3D printed object. Carefully pushing them off the surface of the object is a simple requirement. Use of needle-nose pliers, sand, and/or tweezers.



Sanding

Apart from support removal, sanding is the most common form of post-processing. Generally, FDM 3D prints can have a slightly rough surface, and sanding is the easiest way to smooth it.

When printing a part, it may have a few bobbles and a surface that is not perfectly smooth. The easiest way to remove such blemishes is by using sandpaper. It is a good idea to start with 80-grit sandpaper, followed by 150-grit, 200-grit, and finally 400-grit sandpaper. Finally, 2000-grit is a fine-grit of sanding.



Gluing

Usually, 3D printed parts with PLA can be joined by gluing. This is generally used when connecting parts that cannot be joined in a single piece.

The best glue for PLA is superglue and MDI glue. If you are using PLA, you can use a mixture of white glue and water. Just follow the instructions and glue it.

Sub-topic 3: Preparation of 3D Printer

Wear Safety Goggles



This will lower the risk of eye injury when using a 3D printer.

Do not touch



Depending on the type of 3D printer and the material that's being deposited, it may reach a temperature of up to 200 degrees Celsius. Therefore, touching the 3D printer can cause a painful burn.

Control the Temperature



Controlling the temperature of the 3D draw can lower the risk of injury. Materials are designed to cure and harden at specific temperatures.

Ventilation



With proper ventilation, any toxic or harmful fumes will be flushed away from the surrounding indoor space so that they aren't inhaled.

Sub-topic 3: Preparation of 3D Printer

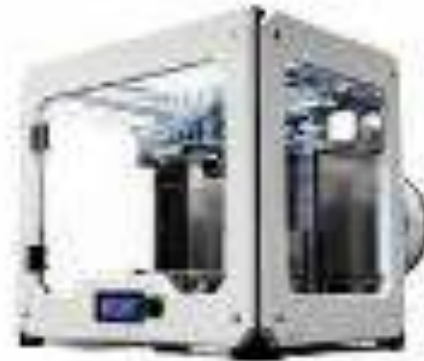

Stay in touch with us



<https://3d4deafproject.eu/>

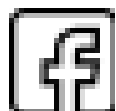

@3d4deaf



@3d4deaf



@3d4deaf



Funded by
the European Union

Funded by the European Union. Views and opinions expressed are however those of the author(s) only and do not necessarily reflect those of the European Union or the European Education and Culture Executive Agency (EACEA). Neither the European Union nor EACEA can be held responsible for them.



www.3d4deafproject.eu



This document may be copied, reproduced or modified according to the above rules. In addition, an acknowledgement of the authors of the document and all applicable portions of the copyright notice must be clearly referenced.

All rights reserved. © Copyright 2023 3D4DEAF